

Welcome to GEA

Company Portrait & Marine Products
GEA Westfalia Separator & GEA Utilities

MICHAEL FIBBE MAY 2017

GEA engineering for
a better world



Systems from one source



Centrifuges f. HFO, MDO & LO



HFO CatfineMaster®



***ScrubberMaster®**
for scrubber



Decanter
for *Membrane
Bioreactor (MBR) Systems



Visco Booster Units Engine
Visco Booster Units Boiler



EnergyMaster®

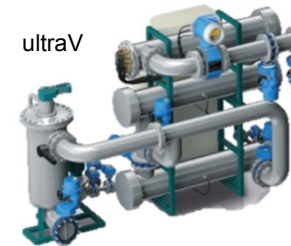
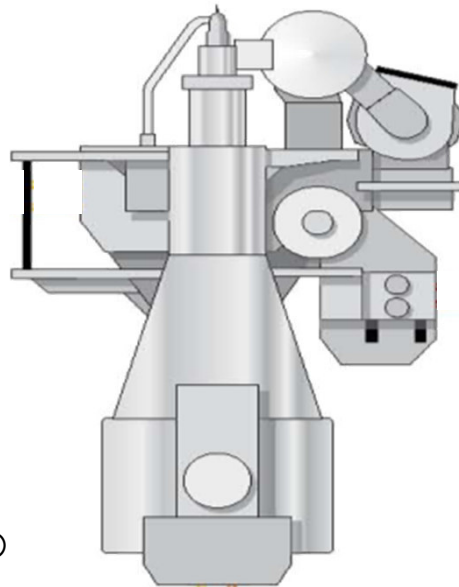

ultraV



marineX

BallastMaster® ultraV & 250 – 500 m³
BallastMaster® marineX 150 – 1500 m³



BilgeMaster® cleandesign
200 – 5000l/h

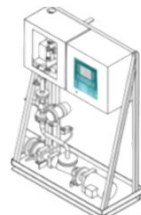

SafetyMaster®



SludgeMaster® 300l/h



sea water distiller
evaporator 5-30t/day



Provision refrigeration plant,
Cooling compressors for
refrigerator rooms,
HVAC, etc



GEA Westfalia Separator Sea Water Distiller

Evaporator SWD 5 to 30 ton/day



from 5 up to 30 ton/day

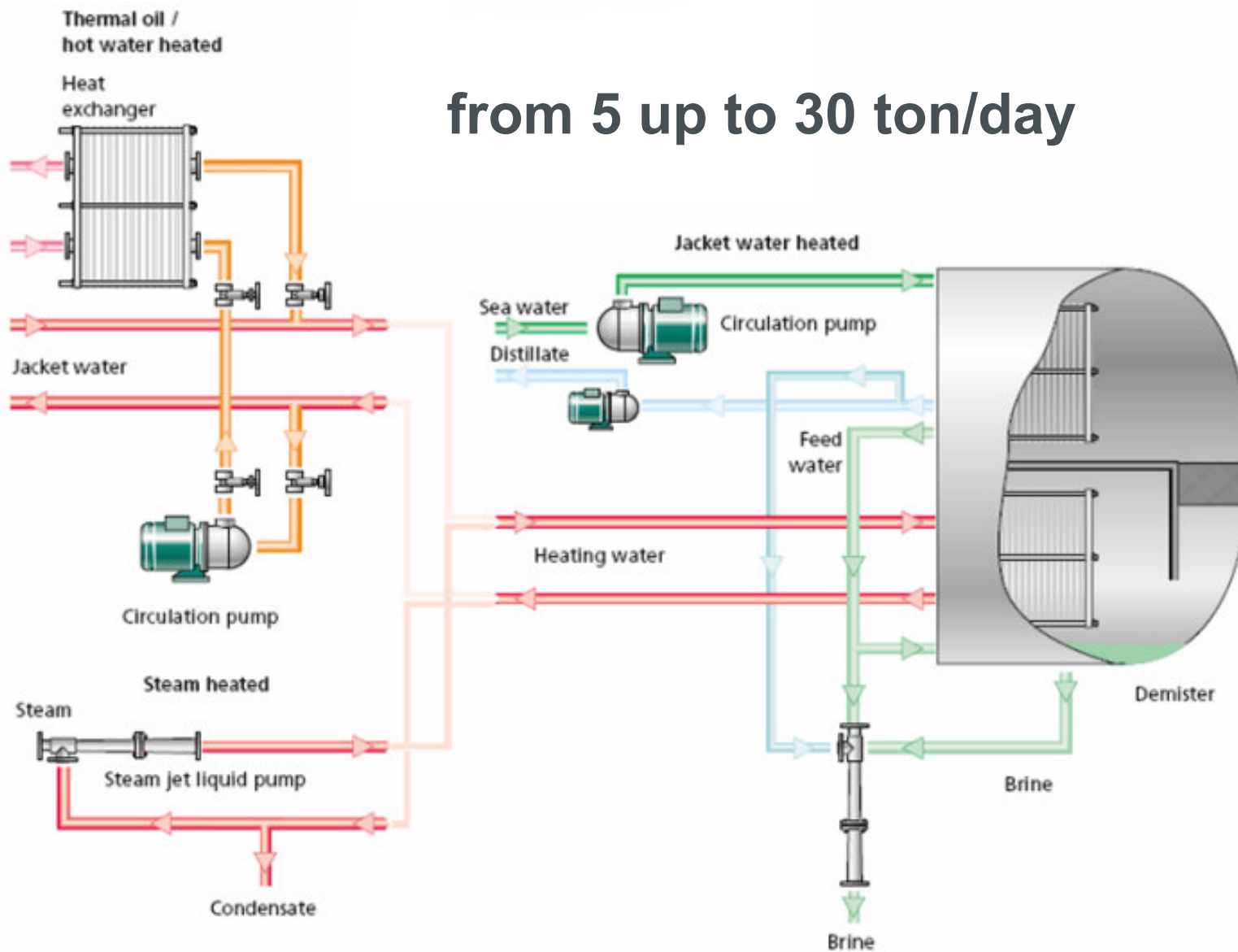

➤ available with Sea water pump, Rehardening filter / Disinfection unit, etc.

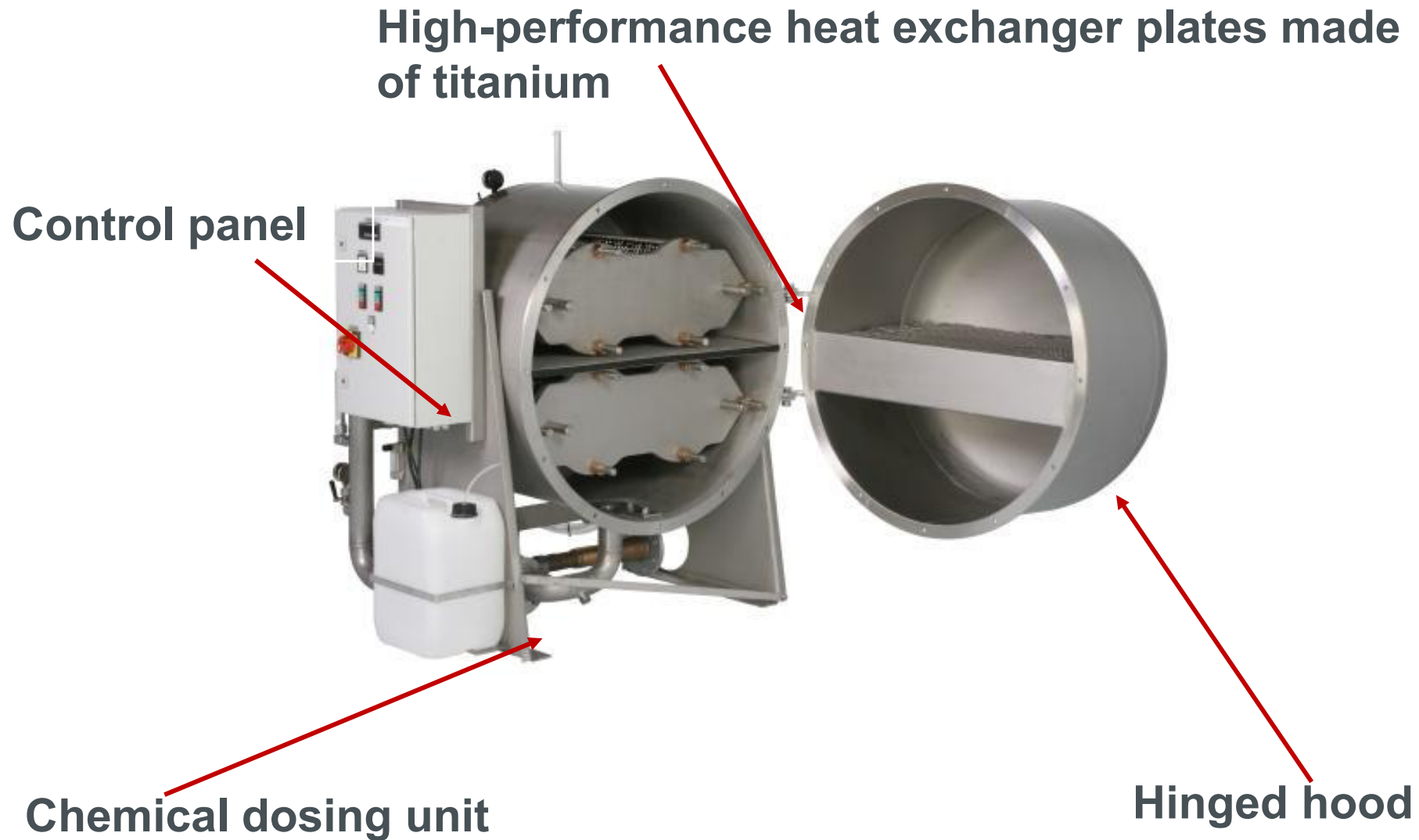

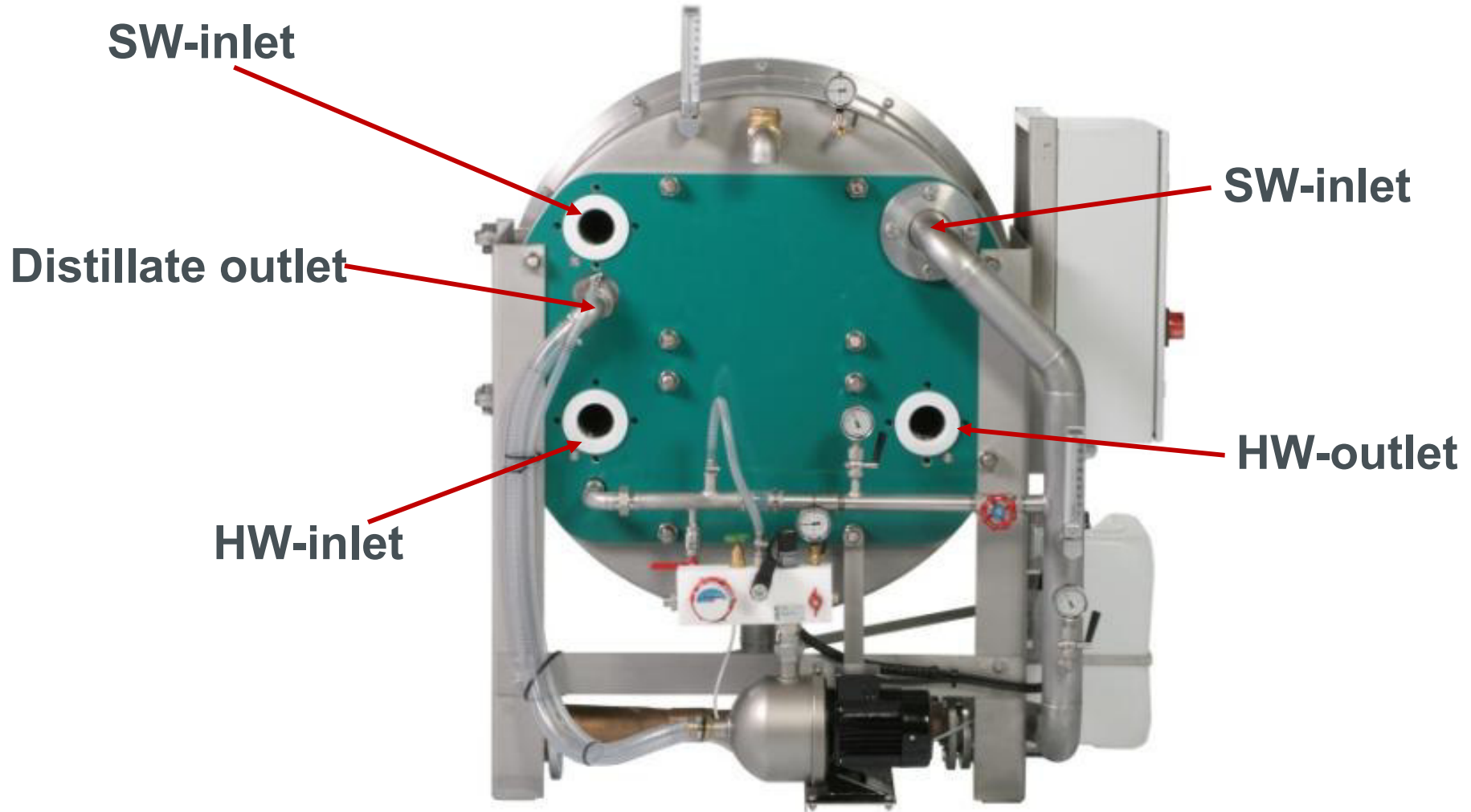

Equipment for Distillate Post-Treatment



**PH-
adjustment /
Rehardening
Filter**

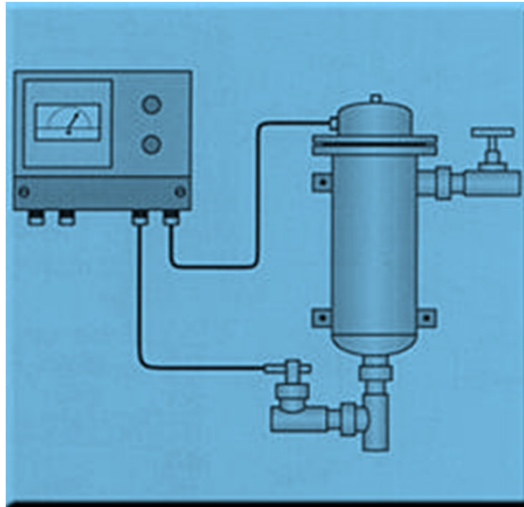

**Disinfection
UV-Sterilizer**



**Silver-Ion
Sterilizer**



**Chlorination
Systems**

