



Marine System Technology

Concepts and High Performance Equipment for the
Engine Room from GEA Westfalia Separator

Time for a New Generation

Smart

The new GEA Westfalia Separator **eagle**class was developed with the know-how of the technology leader in centrifugal separation technology. The innovative separator design and the new GEA Westfalia Separator **unitrol**plus sensor system are setting new standards in the market segments energy, marine, oil field, industry and environmental technology.

Strong

The strong g-force permits throughput capacities of up to 80 m³/h for the first time ever. GEA Westfalia Separator **unitrol**plus assures highest separation efficiency of the different media such as fuel and lube oils, oily water, washing lye etc.

Reliable

The compact, robust construction makes the GEA Westfalia Separator **eagle**class particularly reliable and durable. A further feature is GEA Westfalia Separator **serv&care** – the proactive service of the original manufacturer. This combination ensures maximum availability and economy throughout the entire life cycle.



Contents

4 Overview engine room concepts	22 Flexible systems
4 High Performance Equipment for the Engine Room	22 Custom-Made System Solutions for the Engine Room
6 Manual cleaning separators	23 Separator with Single Components
6 GEA Westfalia Separator minimaXx ®	24 CU Compact Unit – Flexible Modularisation
8 Self-cleaning separators	25 GEA Westfalia Separator centripack – Individual Modularisation
8 Self-Cleaning Separator with Centripetal Twin Pump	26 Sludge treatment
10 Self-cleaning separators	26 Process Overview
10 GEA Westfalia Separator unitrol plus – Lube and Fuel Oil	27 System Concepts for the Future
12 Diesel oil treatment	28 Economical Advantages – Ecological Merits
12 Process Overview	30 Bilgewater treatment
12 Manual Cleaning Solutions	30 Self-Cleaning Centrifugal System
13 Self-Cleaning Solutions	32 Technologies to Protect the Sensitive Marine Ecosystem
14 Heavy fuel oil treatment	33 Flexible Compact Unit Design
14 Process Overview	34 GEA Westfalia Separator SafetyMaster
15 Plant Concepts with a System	36 Fuel oil conditioning system
16 Parallel Operation	36 VBU – GEA Westfalia Separator ViscoBooster Units
18 Lube oil treatment	37 Complete System Between Service Tank and Engine
18 Process Overview	38 Water desalination system
19 Plant Concepts for Efficient Operation	38 SWD – GEA Westfalia Separator SafetyMaster
20 Control units	40 GEA Westfalia Separator BallastMaster ultraV
20 Automatic Process Control – More Safety, More Comfort	42 GEA Westfalia Separator serv&care – Proactive Service for Optimum Reliability on Board
21 GEA Westfalia Separator minimaXx ® – Process Control for Every Requirement	

High Performance Equipment for the Engine Room

Overview engine room concepts

GEA Westfalia Separator Group offers leading technologies and individual systems for marine use. Be it system engineering from one source, high quality of workmanship or the unrivalled worldwide service – GEA Westfalia Separator Group provides a system to rely on.

Product range overview

- Fuel oil treatment
- Fuel oil conditioning system
- Lube oil treatment
- Sludge treatment
- Bilgewater treatment
- Water desalination system
- Hydraulic oil treatment plants
- Ballast water treatment

GEA Westfalia Separator Group supplies separation systems specifically designed for continuous operation under the roughest conditions. This gives you:

- Optimum power output
- Long service life for your engines
- High environmental standards

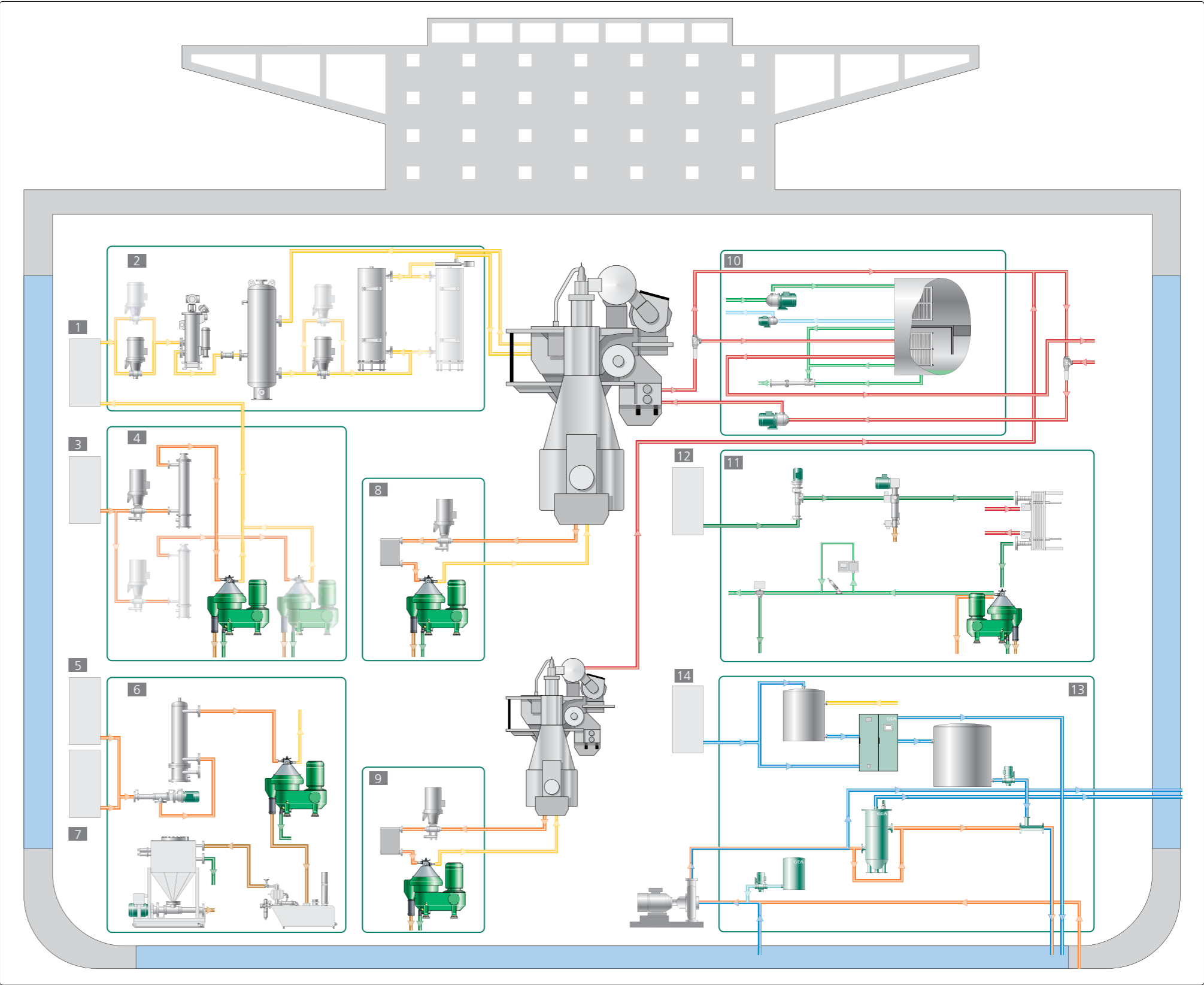

- | | | | | |
|--------------------------------|------------------------|---------------------------|------------------------------|----------------------------|
| 1 Fuel oil service tank | 4 Fuel oil treatment | 7 Lube oil sludge tank | 10 Water desalination system | 13 Ballast water treatment |
| 2 Fuel oil conditioning system | 5 Fuel oil sludge tank | 8 Lube oil treatment M.E. | 11 Bilgewater treatment | 14 Water tank |
| 3 Fuel oil setting tank | 6 Sludge treatment | 9 Lube oil treatment A.E. | 12 Bilgewater tank | |

GEA Westfalia Separator minimaXx®

Manual cleaning separators

Manual cleaning separators with solid wall bowl and single centripetal pump are today used mostly for the treatment of diesel oil and lube oil on smaller ships. They are suitable for clarifying or purifying oils with a low solids content of up to 0.1 percent by vol.

The clean oil is discharged from the bowl under pressure by means of a centripetal pump. The separated solids slide down the underside of the disc into the solids holding space which must be emptied by hand periodically.

Benefits

- Suitable for both clarifying and purifying
- Highly concentrated solids
- Simple construction
- Versatility of application

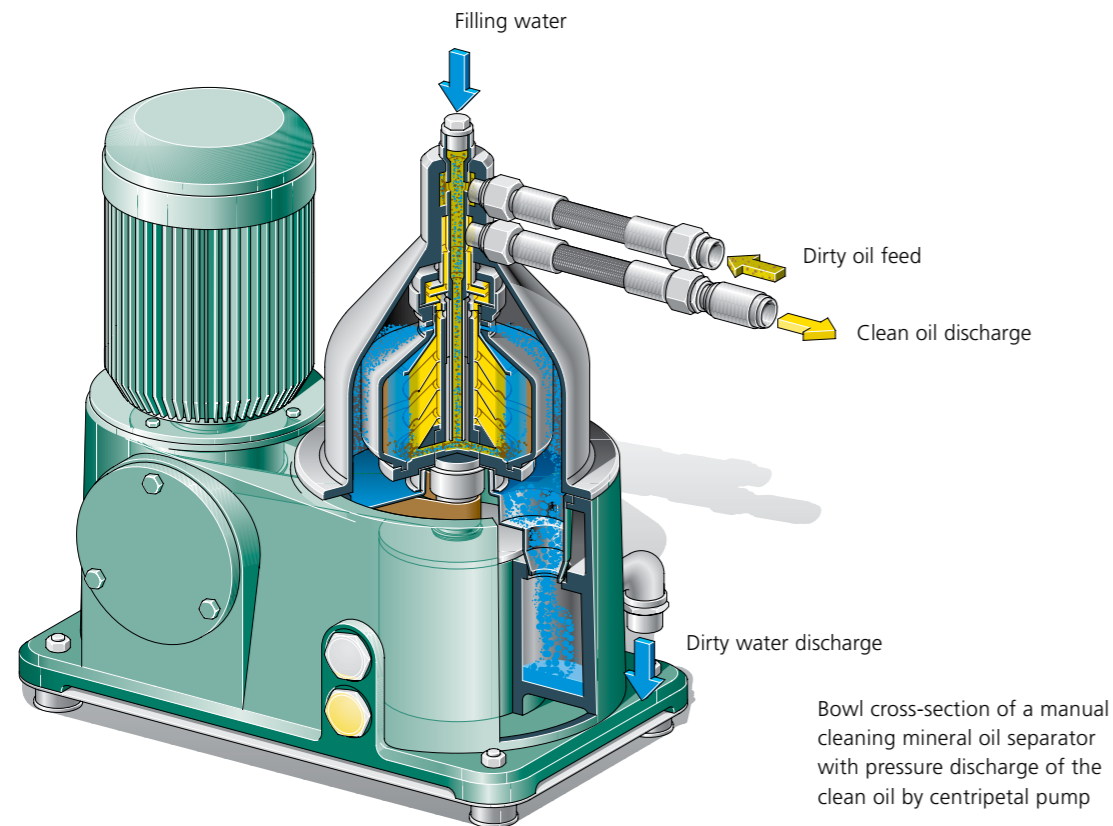

Self-cleaning separators

Self-cleaning separators with disc bowl, single centripetal pump and automatic solids ejection are used where the percentage of solids in the oil is too high for manual cleaning. These are used mainly for the clarification and purification of oils such as gas oil, diesel oil and lube oil. Self-cleaning separators discharge solid matter automatically while the separator is running. This avoids the need to shut down the separator for frequent cleaning.

Self-cleaning separators operate continuously. Total ejections are used with a self-cleaning effect of the disc stack. Labour-intensive and costly measures to clean the discs using CIP systems are not necessary. Optimum separation efficiency over long operating times is ensured. Maintenance work is not required until up to 8000 operating hours (i.e. approx. only once a year).

The clean oil is conveyed to the discharge under pressure by means of a centripetal pump. The separated water flows under gravity via a regulating ring to the discharge.

Benefits

- Automatic operation
- Continuous operating mode
- Self-cleaning effect of the bowl without CIP systems
- Highly concentrated solids
- High separation efficiency
- Can be used as clarifier and purifier
- Closed discharge of the light phase under pressure by centripetal pump
- Low noise level
- Belt drive gives you less wear and tear

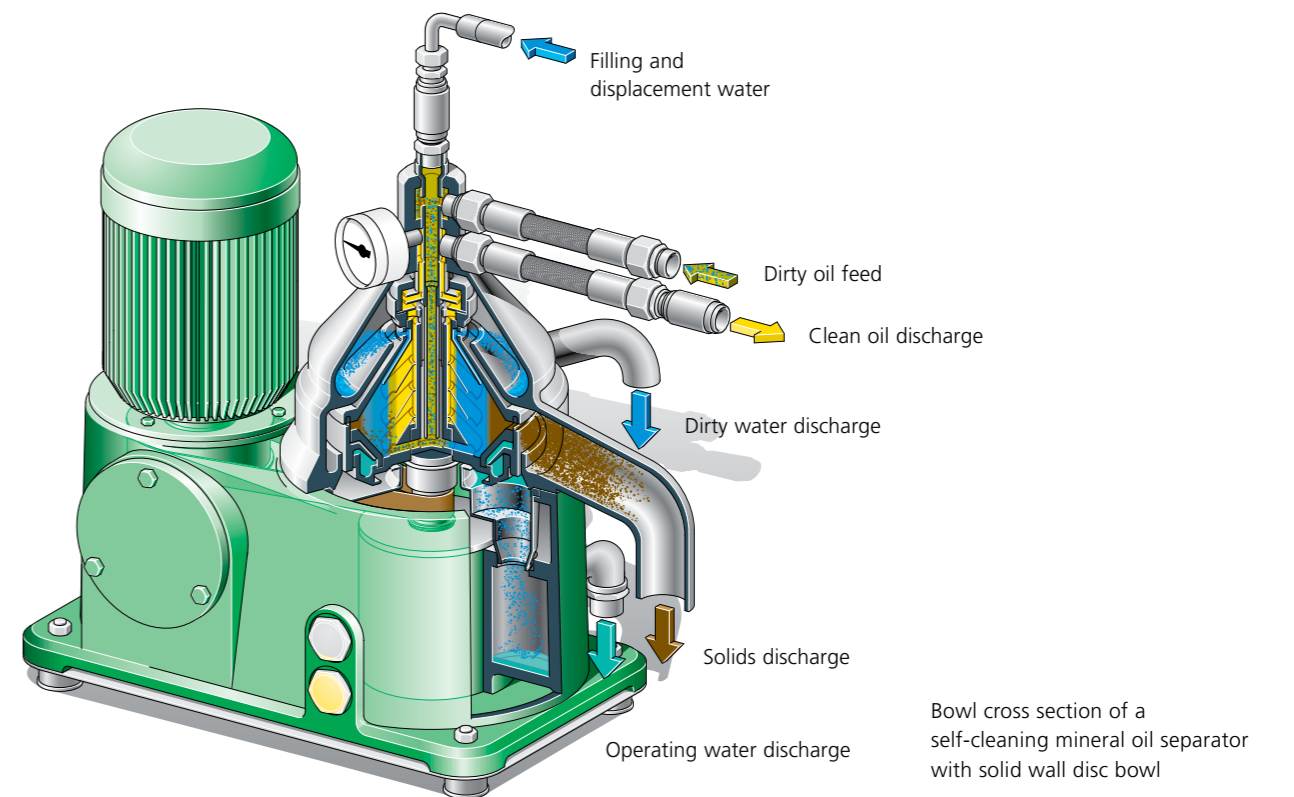

Self-Cleaning Separator with Centripetal Twin Pump

Self-cleaning separators with disc bowl and automatic solids ejection are used where the percentage of solids in the oil is too high for manual cleaning. These are used mainly for the clarification and purification of oils such as gas oil, diesel oil and lube oil. Self-cleaning separators discharge solid matter automatically while the separator is running. This avoids the need to shut down the separator for frequent cleaning.

Self-cleaning separators operate continuously. Solids ejection occurs either by total or partial discharges, or a combination of both. In the case of the total ejection and the combination of total and partial ejections, there is additional self-cleaning of the disc stack. Labour-intensive and costly measures to clean the discs using CIP systems are not necessary. Optimum separation efficiency over long operating times is ensured. Maintenance work is required only after 8000 to 16,000 operating hours.

The clean oil and the separated water are conveyed to the discharge under pressure by a centripetal twin pump.

Benefits

- Automatic operation
- Continuous operating mode
- Self-cleaning effect of the bowl without CIP systems
- Highly concentrated solids
- High separation efficiency
- Can be used as clarifier and purifier
- Closed discharge of the light phase under pressure by centripetal pump
- Low noise level
- Belt drive gives you less wear and tear

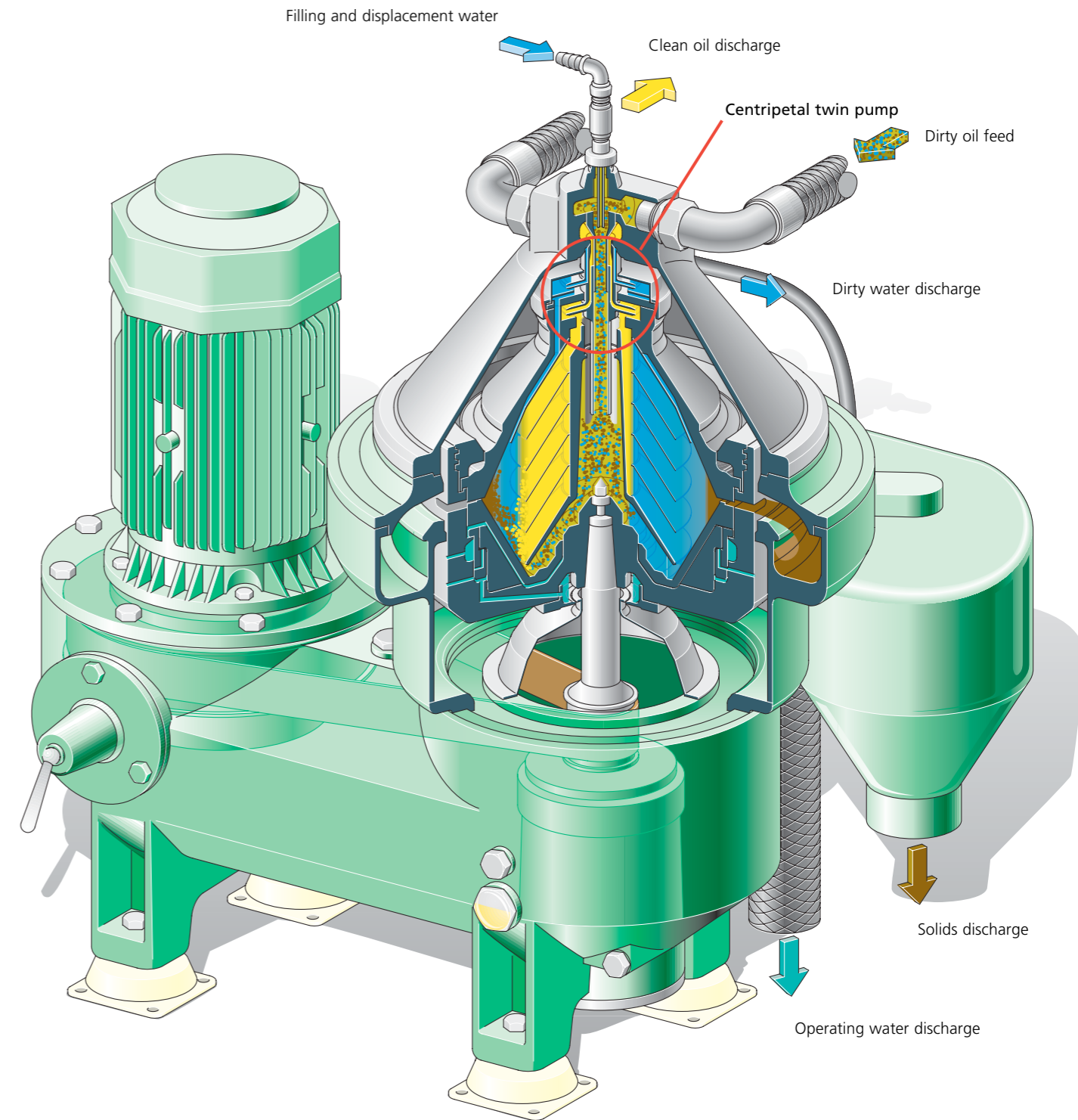

Bowl cross-section of a self-cleaning mineral oil separator with disc bowl

GEA Westfalia Separator **unitrolplus** – Lube and Fuel Oil WMS/SMS in Single Stage

Self-cleaning separators

Modern lube and fuel oil treatment plants from GEA Westfalia Separator Group provide easy handling and optimum separating efficiency in difficult situations. The heart of these plants is a new generation of self-cleaning mineral oil separators with the **unitrolplus**. These separators operate without regulating rings and can be applied for a wide range of lube and fuel oils with a specific density up to 1.01 kg/l.

The essential features of these separators are both the continuous monitoring of the oil for water and the continuous monitoring of the solids holding space for optimum solids filling in one stage. Automatic monitoring means that regulating rings are unnecessary and operating errors caused through manual adjustment are eliminated.

The water content of the oil is checked continuously using the Water Monitoring System (WMS). The water in the oil is separated out and discharged. The Sludge Space Monitoring System (SMS) checks the solids space for separated foreign matter such as cat fines, sand, abrasives and rust.

The oil is displaced prior to a bowl ejection. The precisely defined displacement volume minimises oil losses. A further innovative feature of these separators is the bowl's new hydraulic system (GEA Westfalia Separator **hydrostop**). Extremely short ejection times with the maximum outlet diameter provide for highly concentrated solids. Further disposal measures are simplified, disposal costs reduced and environmental considerations fully taken into account. During total ejections preferred by GEA Westfalia Separator Group the disc stack is also cleaned. Work and cost intensive measures for cleaning the disc stack by CIP systems are not necessary; this

ensures optimum separating efficiency over a long period of operation. Maintenance work is required only after 8000 to 16,000 operating hours.

Just a few basic models are sufficient to cover all capacity ranges. This makes spare parts storage and servicing very economical.

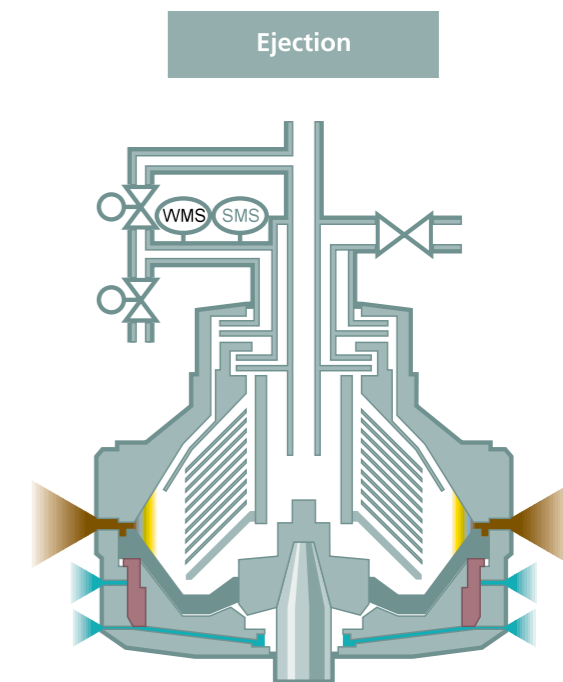
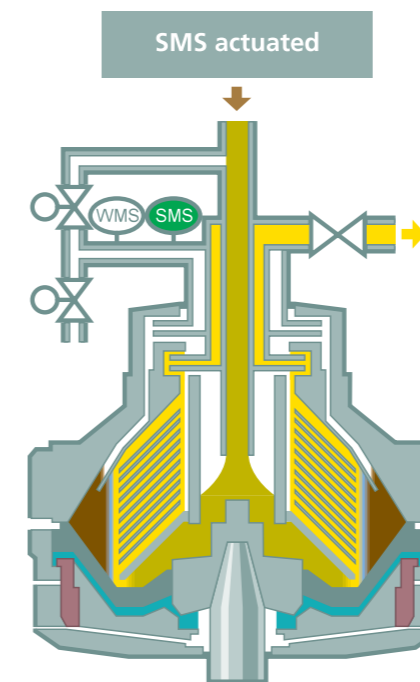
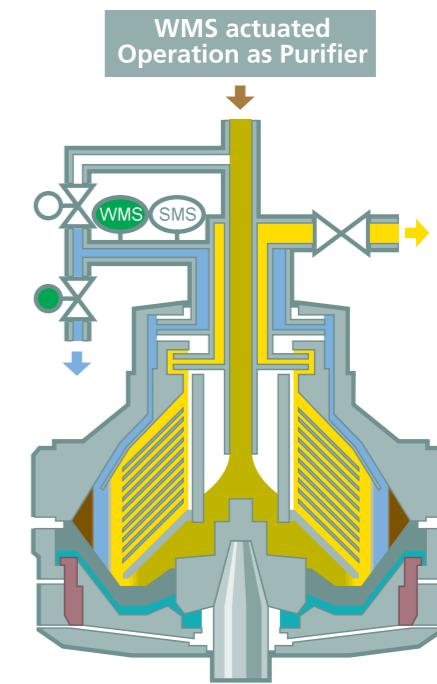
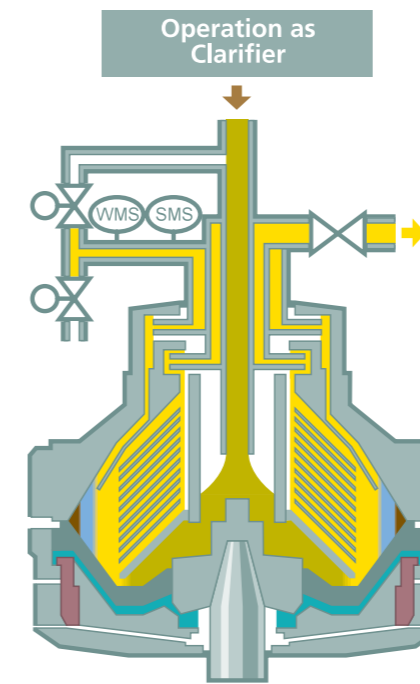
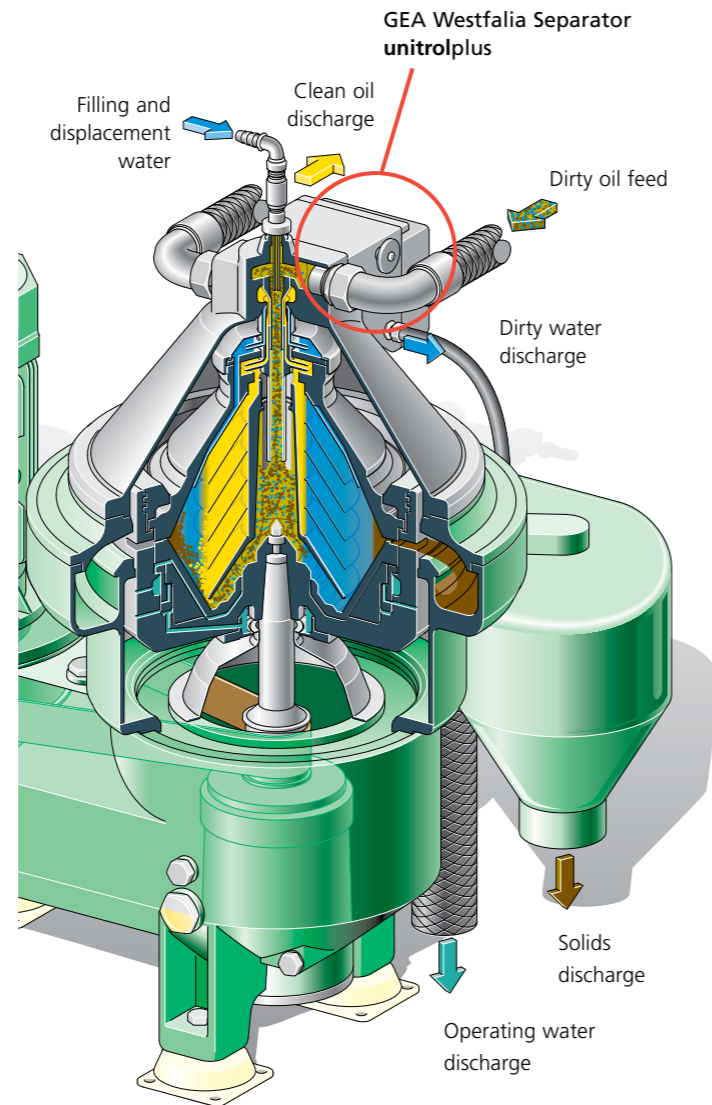

Benefits

- GEA Westfalia Separator **unitrolplus** – a new sensor system for automatic monitoring and control for water and solids content monitoring
- Reliable treatment of particularly heavy and severely contaminated fuels
- Self-thinking system – ideal also for the unmanned engine room
- Treatment of fuel oils up to 1.01 kg/l
- Lube oil treatment of 2-stroke cross head and 4-stroke trunk piston engine
- Regulating rings are not required

- Automatic adjustment as clarifier or purifier
- High separation efficiency even in critical situations
- Automatic bowl ejection
- Highly concentrated solids
- Continuous processing
- Self-cleaning effect of the bowl and the disc stack by total ejection
- Versatility of application
- Safe operation
- Belt drive gives you less wear and tear
- Low noise level

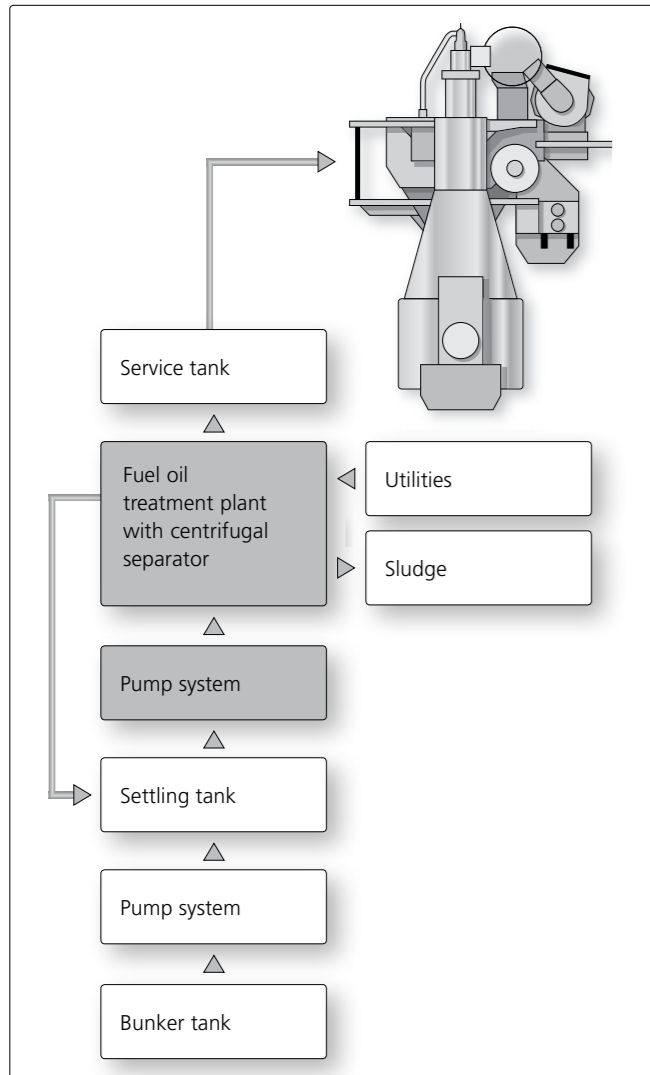

Process Overview

Diesel oil treatment

Centrifuges are essential for the efficient control and removal of solids and water from fuel oils in fuel oil safety treatment systems; they will continue to be so in the future.

Efficient treatment protects the diesel engine from wear to important components such as cylinder liners, pistons, piston rings and the injection system.

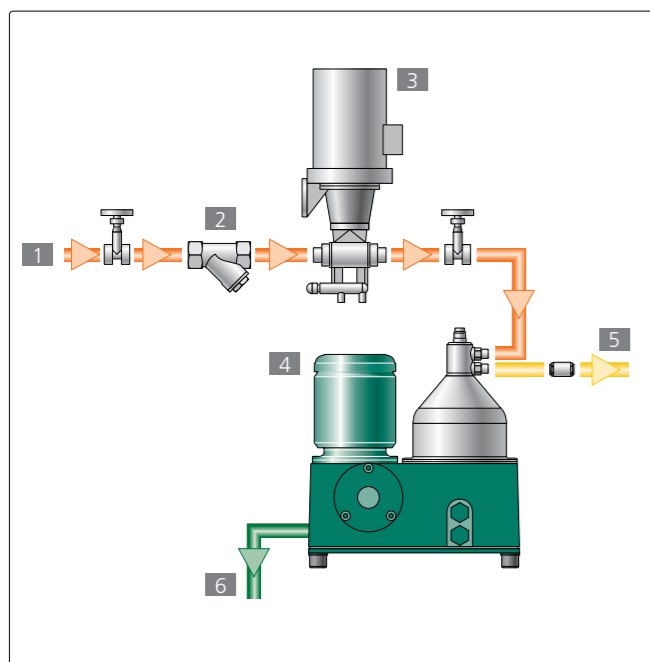

Manual Cleaning Solutions

This Pipe Installation Diagram (PID) shows examples of manual cleaning centrifugal systems for diesel oil treatment.

- 1 Dirty oil feed
- 2 Strainer
- 3 Feed pump
- 4 Manual cleaning separator
- 5 Clean oil discharge
- 6 Dirty water discharge

Piping and installation system for marine diesel oil treatment system with manual cleaning separator without heater

Self-Cleaning Solutions

Diesel oil treatment

This Pipe Installation Diagram (PID) shows examples of self-cleaning centrifugal systems for diesel oil treatment.

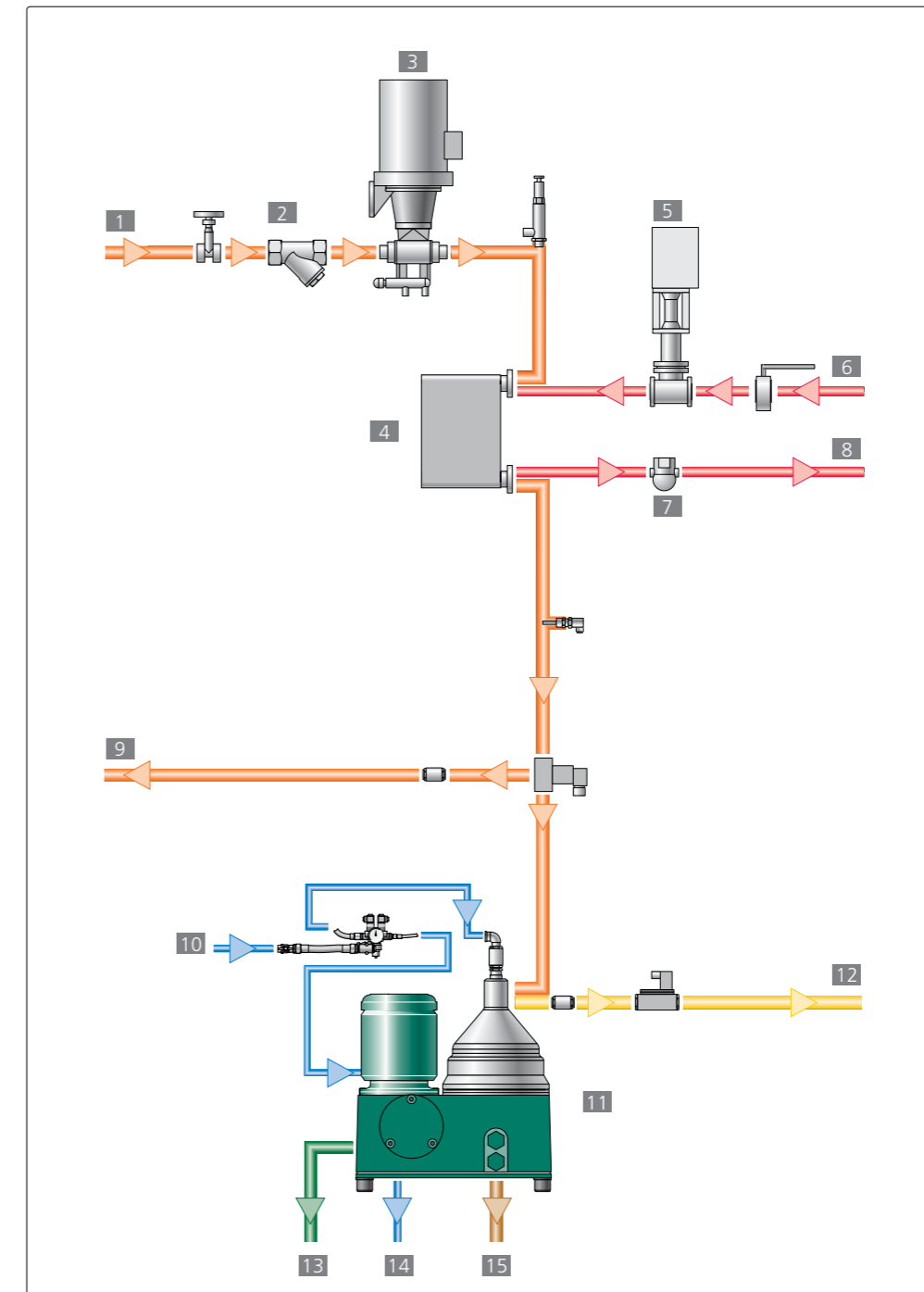

Piping and installation system for marine diesel oil treatment system with self-cleaning separator with electric heater

- 1 Dirty oil feed
- 2 Strainer
- 3 Feed pump
- 4 Preheater
- 5 Regulating valve
- 6 Steam
- 7 Steam trap
- 8 Condensate
- 9 Dirty oil return
- 10 Operating water
- 11 Self-cleaning separator
- 12 Clean oil discharge
- 13 Dirty water discharge
- 14 Operating water discharge
- 15 Solids discharge

Process Overview

Heavy fuel oil treatment

Centrifuges are essential for the efficient control and removal of solids and water from fuel oils in fuel oil safety treatment systems; they will continue to be so in the future.

Low-grade fuels from different refining processes such as atmospheric or vacuum distillation as well as from conversion plants such as catalytic cracker or Visbreaker process must be purified efficiently too.

This treatment protects the diesel engine from wear to important components such as cylinder liners, pistons, piston rings and the injection system. The whole plant concept for fuel oil treatment is rounded off with GEA Westfalia Separator **ViscoBooster**Units.



Single-stage treatment plant for fuel oil with separator with GEA Westfalia Separator **unitrolplus**

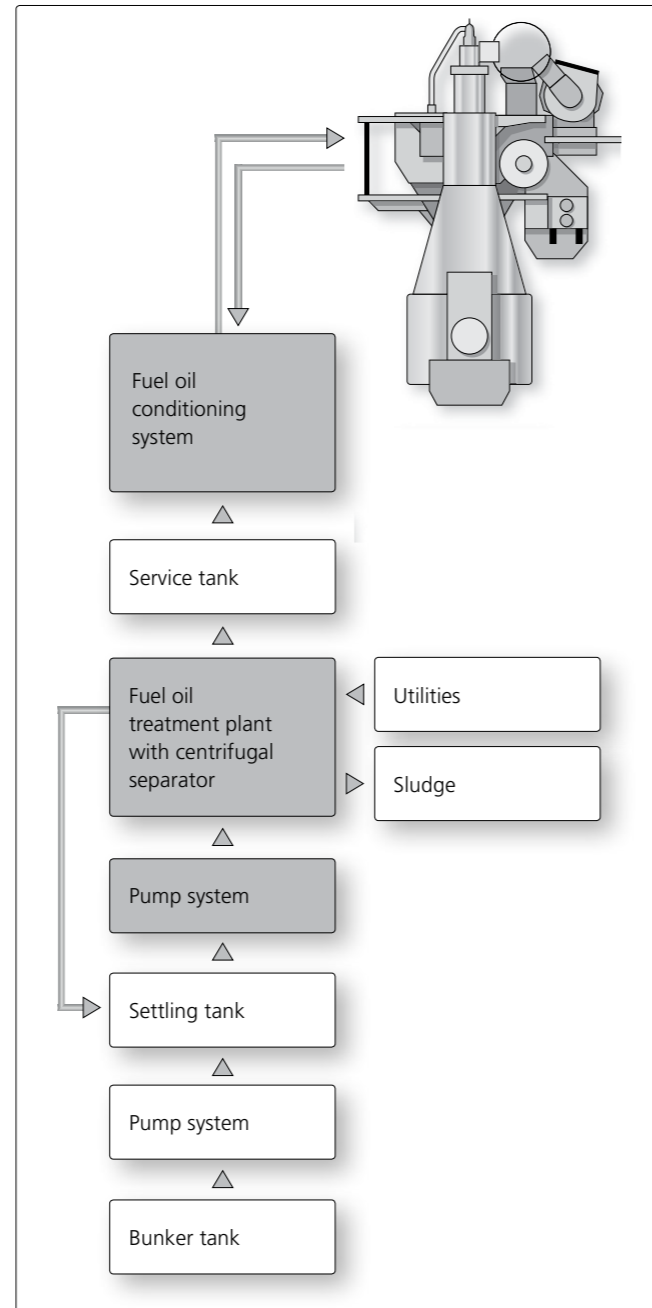

Plant Concepts with a System

Under normal circumstances, GEA Westfalia Separator Group recommends single-stage treatment for heavy fuel oils.

The high efficiency of separation with the GEA Westfalia Separator **unitrolplus** WMS/SMS in a single-stage process ensures low wear on the engine. The high reliability and long service intervals ensure low operating costs and continuous, unattended automatic operation for months. The stand-by centrifuge can be saved for occasional use in abnormal conditions – for example, during increased solids loading in heavy seas. It can also be used for occasional topping-up of the diesel oil day tank. An additional separator for diesel oil treatment is not necessary.

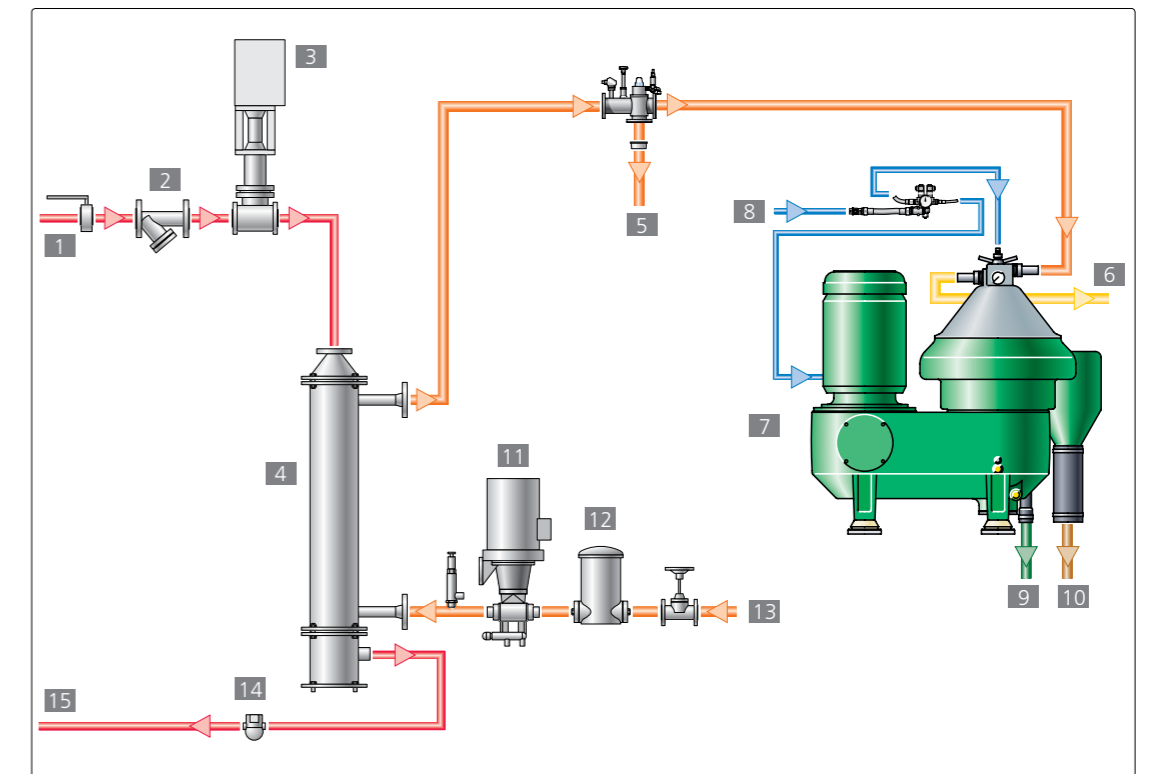

- | | | | |
|--------------------|---------------------------|-------------------------|-------------------|
| 1 Steam | 5 Dirty oil return | 9 Dirty water discharge | 13 Dirty oil feed |
| 2 Strainer | 6 Clean oil discharge | 10 Solids discharge | 14 Steam trap |
| 3 Regulating valve | 7 Self-cleaning separator | 11 Feed pump | 15 Condensate |
| 4 Preheater | 8 Operating water | 12 Filter | |

Parallel Operation (High Water Content)

Heavy fuel oil treatment

A stand-by centrifuge operating in parallel is recommended in emergencies when the water content in the fuel is greater than 10 percent by volume.

The effective throughput of each machine should be reduced to 50 percent. Splitting the feed across two machines and effectively doubling the dwell time of the fuel in the centrifuges allows the machines to remove the excess water effectively and quickly.

This gives the following benefits

- Automatic total ejection of both centrifuges with optimally filled solids holding space
- Longer intervals between solids ejections
- Low water consumption
- Reduced sludge tank loading
- Lower disposal costs

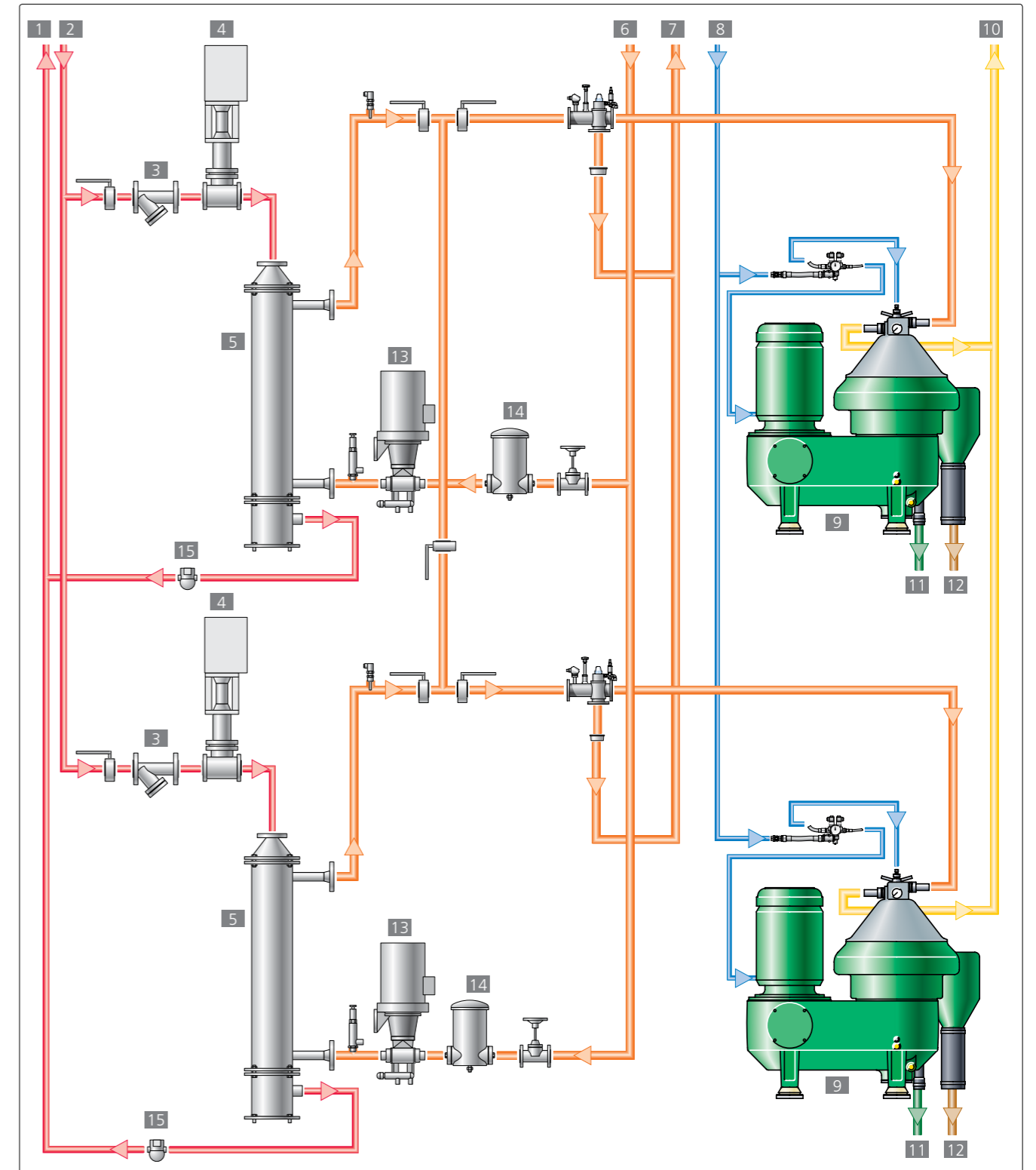
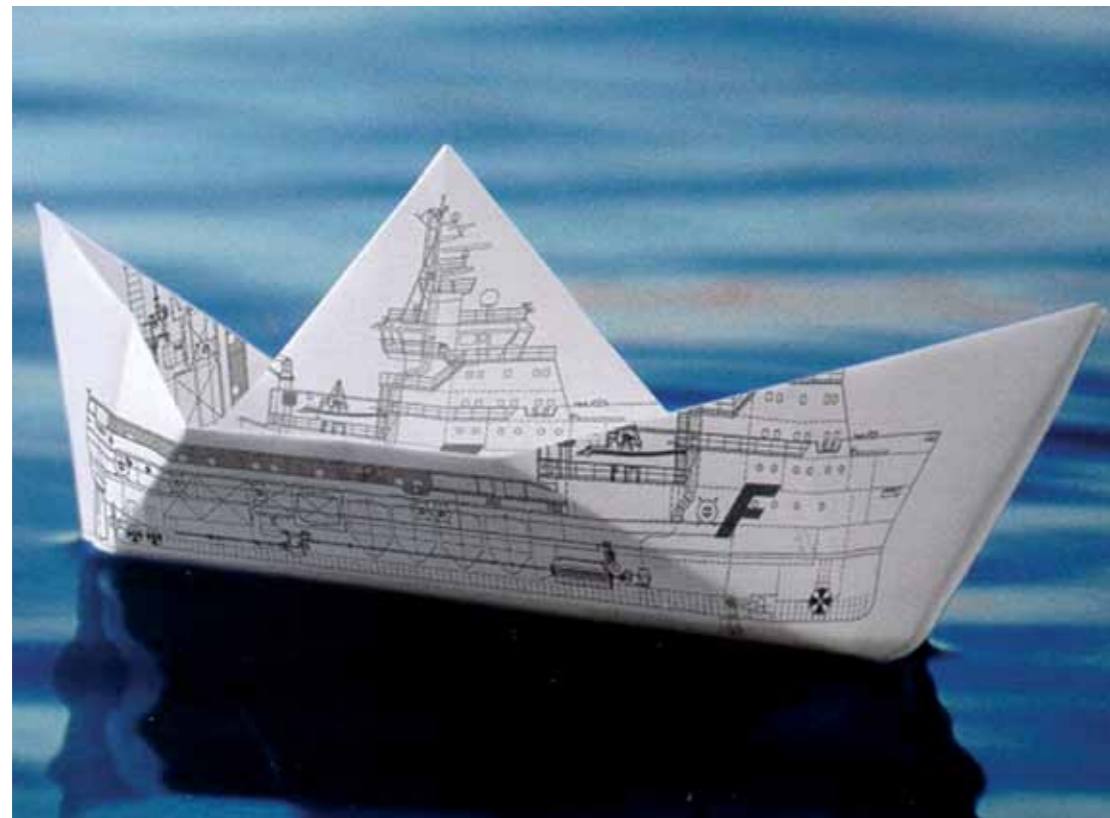

1 Condensate	5 Preheater	9 Self-cleaning separator	13 Feed pump
2 Steam	6 Dirty oil feed	10 Clean oil discharge	14 Filter
3 Strainer	7 Dirty oil return	11 Dirty water discharge	15 Steam trap
4 Regulating valve	8 Operating water	12 Solids discharge	

Fuel oil treatment plant with GEA Westfalia Separator **unitrolplus** and activated stand-by separator for parallel operation.

Process Overview

Lube oil treatment

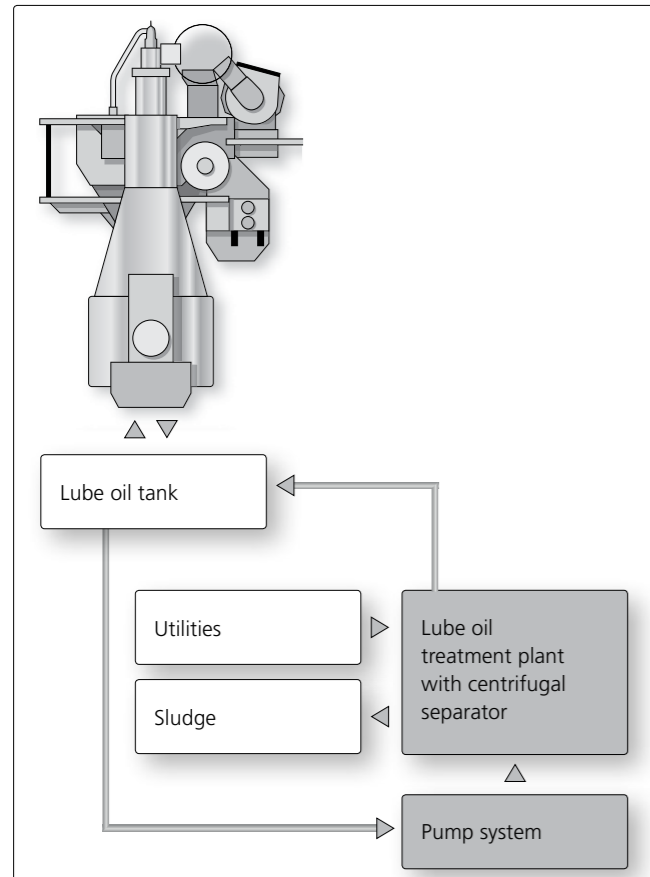

Centrifugal separators are the most widespread method of lube oil treatment. The separator is located in a by-pass loop within the lube oil treatment system.



Schematic illustration of a lube oil treatment plant with manual cleaning separator.

Plant Concepts for Efficient Operation

Self-cleaning mineral oil centrifuges are chiefly used for the purification and dewatering of lube oils, especially when there is a requirement for 24-hour, unattended operation.

All GEA Westfalia Separator Group marine separators for the treatment of fuel and lube oil have identical design features allowing the use of common components. This simplifies store management and maintenance immensely.

The whole range of centrifuges is available for efficient and reliable treatment of lube oil.

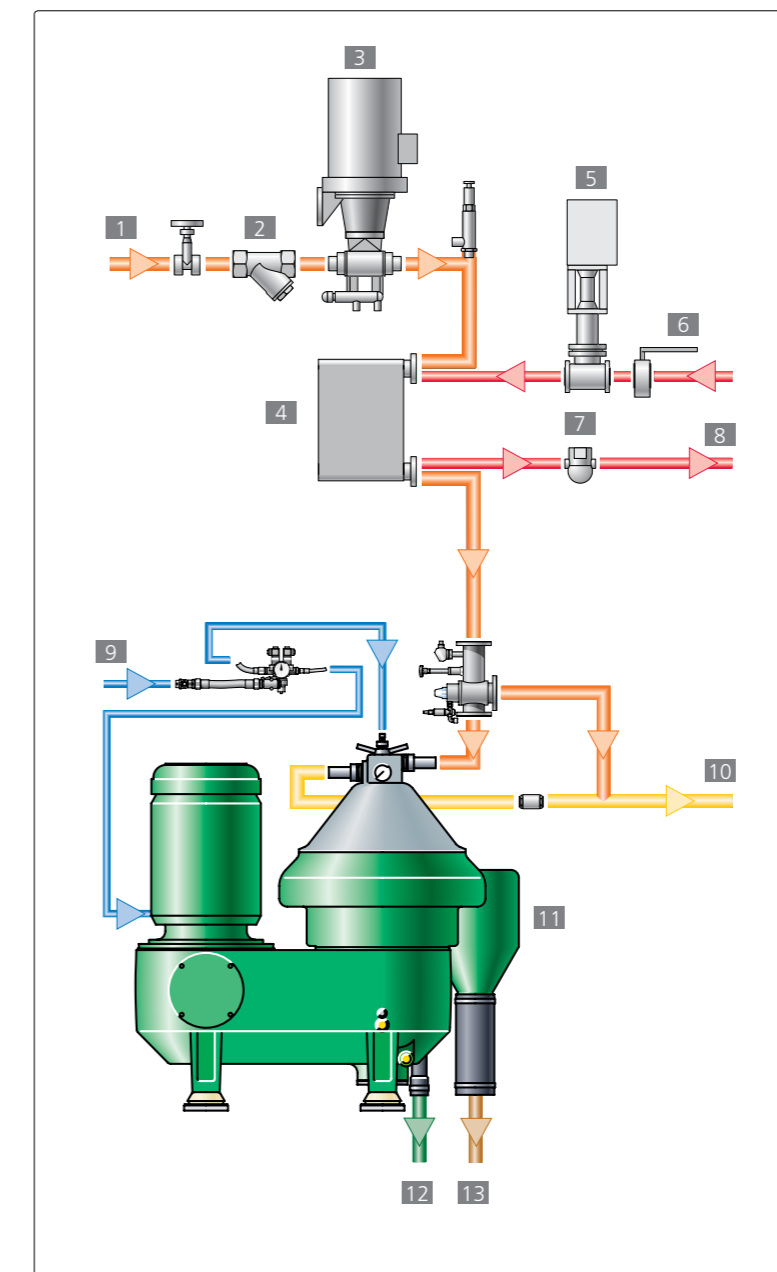

- 1 Dirty oil feed
- 2 Strainer
- 3 Feed pump
- 4 Preheater
- 5 Regulating valve
- 6 Steam
- 7 Steam trap
- 8 Condensate
- 9 Operating water
- 10 Clean oil discharge
- 11 Self-cleaning separator
- 12 Dirty water discharge
- 13 Solids discharge

Schematic illustration of a lube oil treatment plant with self-cleaning separator.

Automatic Process Control – More Safety, More Comfort

Control units

For GEA Westfalia Separator **unitrolplus** and
centripetal twin pump system.



Display with
backlighting and 4 lines

Keys F1 – F4
Soft keypad, screen
dependent

Status LEDs

Keys 1 – 0,
Function keypad with
fixed allocation



Easy handling by
Micro Memory Card
which stores setting
and history data for
D10 and E40.

D10 with
text display

Modern control and monitoring systems, using the latest PLC modules, ensure a high degree of operating safety and user comfort.

They perform the automatic control of the ejection cycles and the monitoring of the self-cleaning separators. The ejection programs are preselectable. Partial or total ejections are initiated in adjustable, periodic intervals with prior displacement of the oil from the bowl.

The standard control unit is designed for unattended operation of a separator.



E40 with graphic
display and
Profibus DP

GEA Westfalia Separator **minimaXx**® – Process Control for Every Requirement

- 1 **Motorstarter box**
Motorstarter separator
Motorstarter feed pump
- 2 **OMB 220**
Overflow monitoring box
Water seal broken alarm
- 3 **Control unit MC-1**
Motorstarter separator
Motorstarter feed pump
Flow monitoring FAH
- 4 **Control unit CC-1**
Motorstarter separator
Motorstarter feed pump
Flow monitoring FAH
Temperature monitoring TAL/TAH
Preheater interlocking
- 5 **Control unit CD-1**
Control and monitoring
system for self-cleaning
GEA Westfalia Separator
minimaXx® separator.



1



2



3



4



5

Motorstarter separator
Motorstarter feed pump
Flow monitoring FAH
Flow monitoring FAL
Clean oil outlet
Temperature monitoring TAL / TAH
Preheater interlocking
Sludge pump control
D10

Custom-Made System Solutions for the Engine Room

Flexible systems

Design engineers have to be flexible with the planning of an engine room. GEA Westfalia Separator Group has, therefore, thought of everything.

Separators with single components, modular compact units or individually installed GEA Westfalia Separator centripack systems give customers flexible systems designed precisely for their needs.



- 1 Separator with single components
No modularisation
- 2 CU – Compact Unit
Flexible modularisation
- 3 CP – GEA Westfalia Separator centripack
Individual modularisation



Separator with Single Components

When planning the detail engineering of an engine room, design engineers need to construct plants precisely to meet customers' needs.

GEA Westfalia Separator Group helps its customers develop individual systems by making all its constructive components available separately. This way systems can be adapted and built to the special needs that may apply.



Examples of elements that can be ordered separately

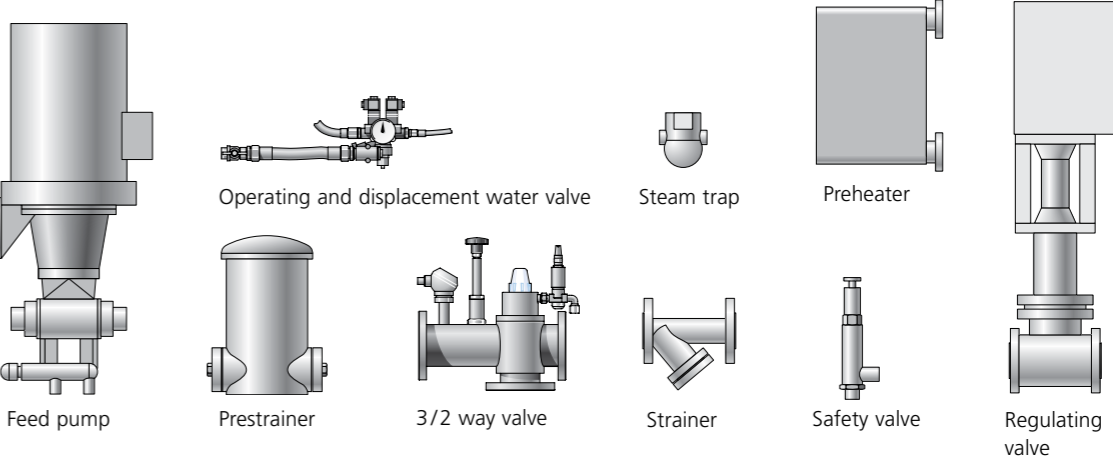

CU Compact Unit – Flexible Modularisation

Flexible systems

In addition to the detail engineering of single components there is the need for simple block engineering. CU compact units provide a modular design to meet this need.

The modular CU compact units offer the opportunity to use flexible, low cost modules. All units are mounted on bases that can be connected easily, even in a confined area.



GEA Westfalia Separator centripack – Individual Modularisation

The centripack is a compact, self-contained treatment plant package system, ready for connection. All elements necessary for safe and efficient oil treatment are mounted ready for connection in a space-saving arrangement on a sturdy foundation frame. These include separators, motors, pumps, pretrainer, alarm system and a control and monitoring system.

The discharge pipes for solids and water as well as the frame drain pipe are led through the foundation frame.

The design makes possible space-saving installation direct in corners or against walls. It is also possible

to install several modules side-by-side to form a complete plant. The centripack is completely assembled and function tested by GEA Westfalia Separator Group; faulty installation of single operating components on site is thus eliminated. The unified design also saves money and makes maintenance easier.

The centripack is available either with self-cleaning separators and control unit including control and monitoring equipment for unmanned operation, or with manual cleaning separators.

The centripack modules are available with one to five separators depending on requirements.



GEA Westfalia Separator centripack – complete ready-to-connect module for the treatment of fuel oil

Process Overview

Sludge treatment

The trend towards burning higher viscosity and higher density fuel oils together with an increasingly common usage of residuals as the fuel for medium speed diesels engines means that the amount of sludge being created from both fuel and lube oil systems is increasing.

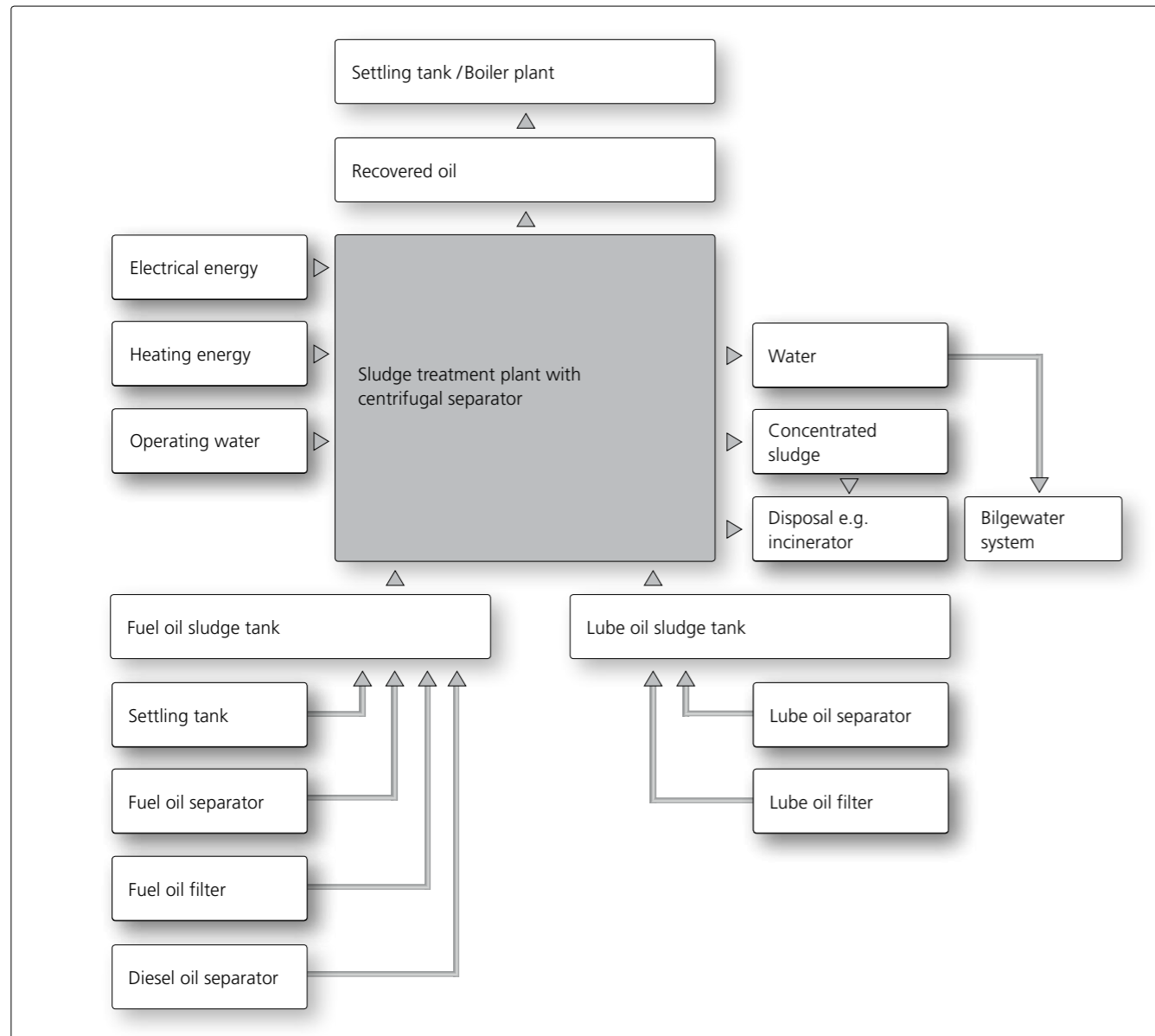

System Concepts for the Future

The sludge is pumped from the sludge tank by an eccentric screw pump and is fed via a heater to the centrifugal separator.

tank where final concentration takes place. Excess water and oil is allowed to overflow back to the sludge tank.

The sludge components of water, oil and solids are separated in the separator by centrifugal force. The recovered oil and water is discharged under pressure by centripetal pumps.

The concentrated sludge is pumped from the unit automatically by a solids discharge pump controlled by a level switch.

A microprocessor-based control cabinet supervises and controls the complete concentration process.

The concentrated sludge is discharged intermittently via the sludge transfer unit into a heated sedimentation

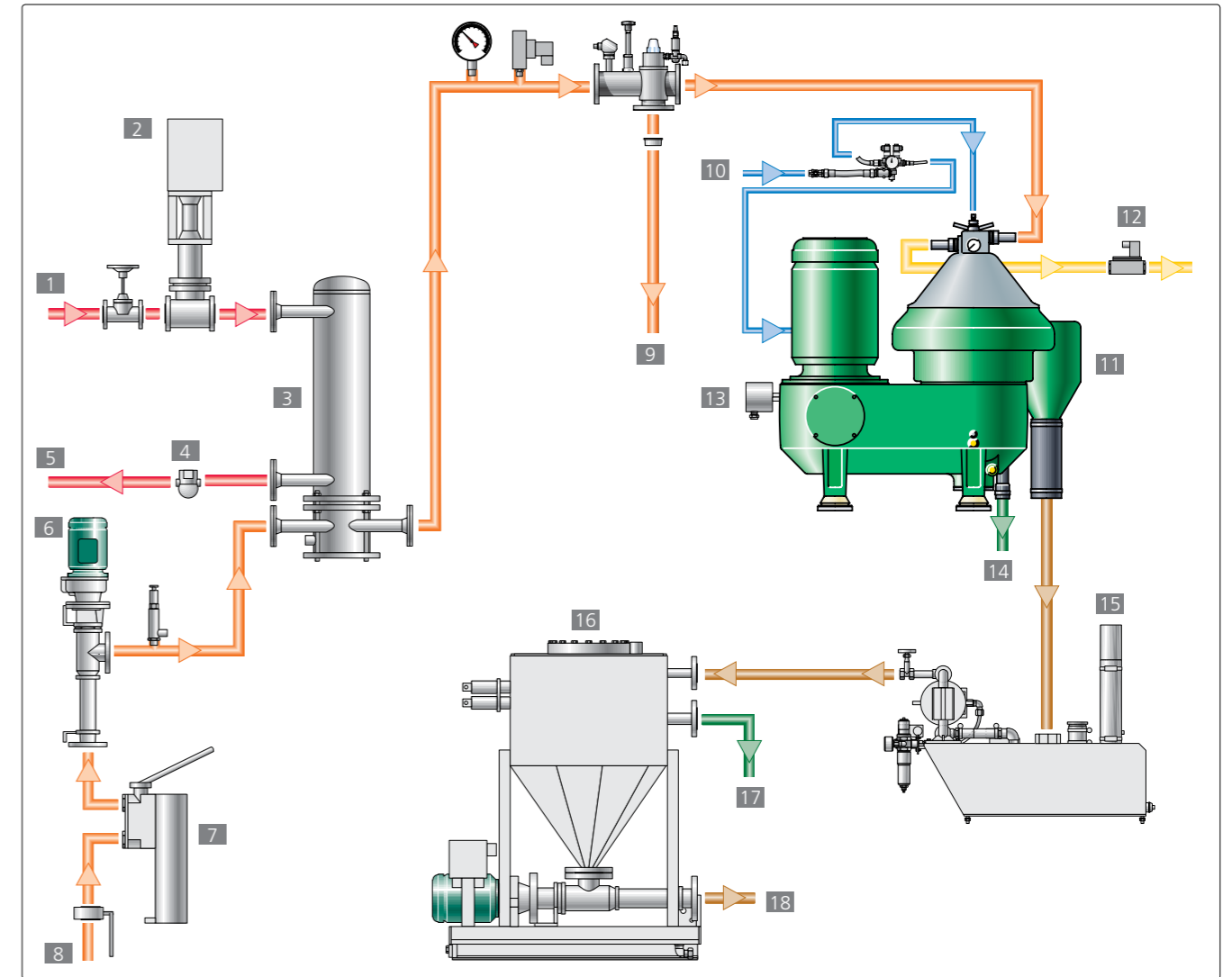

- | | | | | |
|--------------------|-------------------|--------------------------|------------------------------|------------------------|
| 1 Steam | 5 Condensate | 9 Dirty oil return | 13 Vibration monitoring | 17 Oily water |
| 2 Regulating valve | 6 Feed pump | 10 Operating water | 14 Dirty water discharge | 18 Concentrated sludge |
| 3 Preheater | 7 Filter | 11 Centrifugal separator | 15 Sludge transfer unit | |
| 4 Steam trap | 8 Oil sludge feed | 12 Clean oil discharge | 16 Sludge concentration unit | |

Economical Advantages – Ecological Merits

Sludge treatment

Oily sludge mainly consisting of oil, water and solids can amount to 2.5 percent of the marine fuels consumed. Indeed many port authorities use this figure when carrying out ship inspections.

With increasing environmental awareness as well as strict regulations and controls, most operators dispose of this sludge by incineration or by shoreside disposal using contract companies. In either case sludge disposal is becoming an expensive problem for ship owners today.

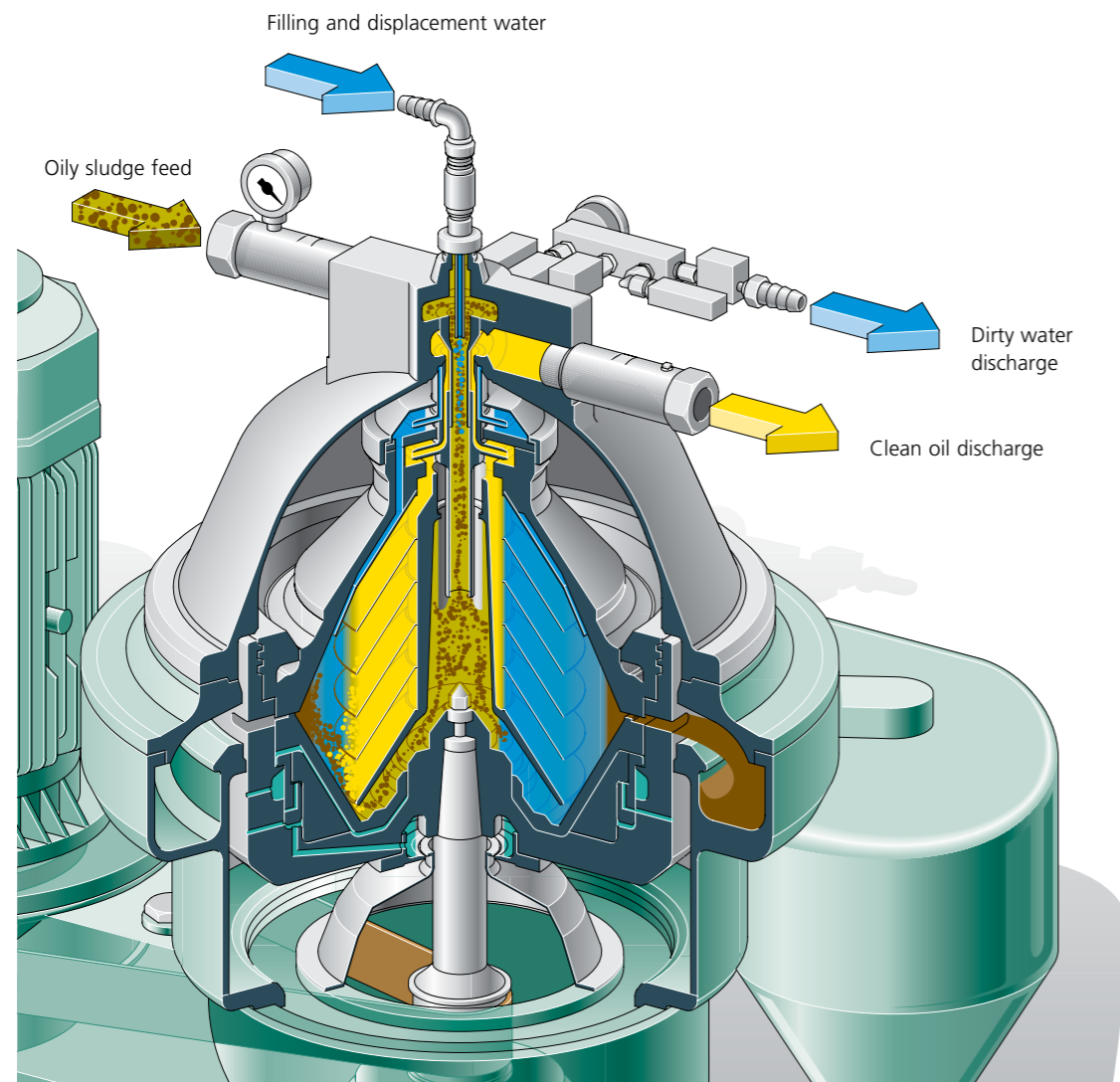

The GEA Westfalia Separator Group sludge treatment plant incorporating a specially designed centrifugal separator is capable of reducing the volume of sludge for disposal by up to 90 percent. In addition, fuel oil is recovered for re-use and recovered lube oil can be used as boiler fuel.

Benefits

- Saves up to 90 percent disposal costs
- Recovers valuable fuel oil
- Unburdens the bilgewater system from oil residues
- Protects our sensitive marine ecosystem

Treatment system for oily and watery sludge with self-cleaning centrifugal separator to reduce the disposal costs

Separation results sludge treatment

MV Fantasy

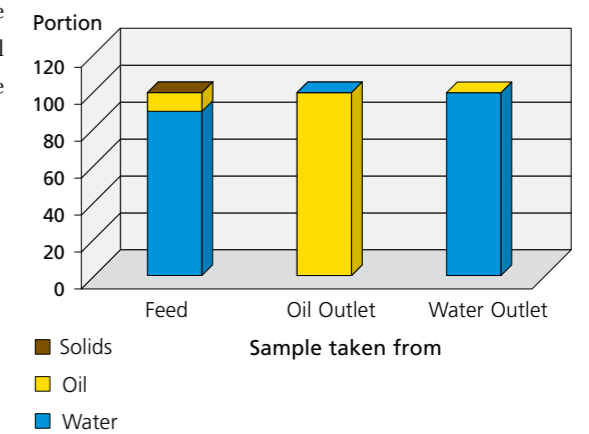

	% (by vol.)	% (by vol.)	% (by vol.)
Oil	10.0	99.6	0.5
Water	89.6	0.4	99.49
Solids	0.4	0.0	0.01



Self-Cleaning Centrifugal System

Bilgewater treatment

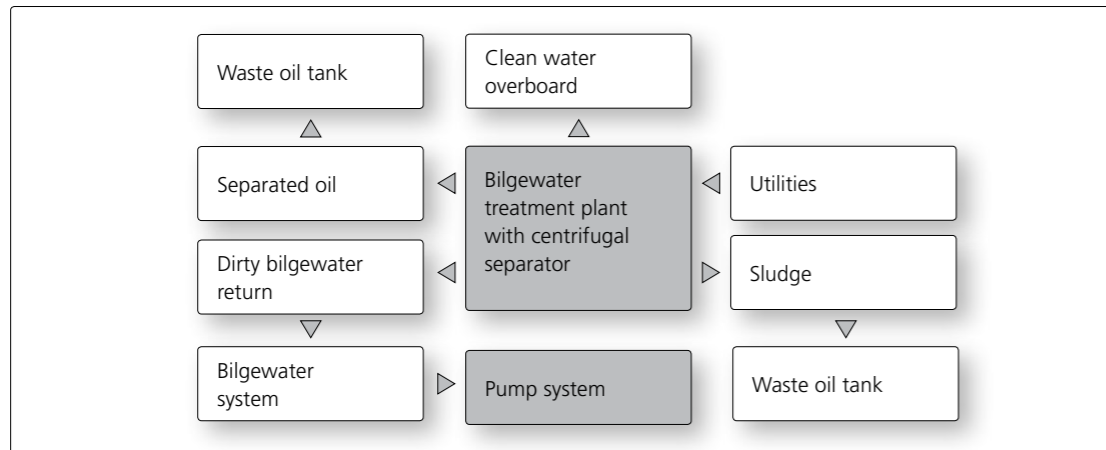

The treatment of bilgewater on board ships is strictly controlled by national and international laws.

Bilgewater may only be discharged into the sea after prior de-oiling with specially approved treatment systems. The maximum oil content must not exceed 15 ppm. The limit has even been reduced to 5 ppm in special areas.

15 ppm is too much

Oily water from ship operation may only be discharged into the sea if the residual oil content in the effluent is below 15 ppm. 15 parts of oil to one million parts of water seems small but GEA Westfalia Separator Group believes this is still too high. Moreover, practice has shown that this value is not attained in many conventional plants under practical operation conditions anyway. The further we can reduce this value, the greater the benefit for our oceans.



Bilgewater is a mixture of the following constituents:

- Sea and cooling water leakages
- Fuel and lube oil leakages
- Drainages from settling and sludge tanks
- Effluent from various cleaning processes
- Soot and dirt particles

So That Our Water Stays As Nature Made It – Clean

The product (i.e. oily water) is sucked up from the oily water tank or engine room bilge and fed by the feed pump through the automatic filter and preheater via the feed valve to the separator. The automatic filter prevents coarse particles from reaching the bowl and blocking the rising channel within the disc stack. During the start-up or ejection program it is led back into the oily water tank. The product flows from above into the centre of the separator bowl. The heavy water phase is separated from the finest oil particles and then conveyed under pressure by a centripetal pump to

the discharge. The separated impurities accumulated in the sludge space are discharged into the sludge tank periodically. The clean water is supervised by an oil monitor before being discharged into the environment. The residual oil content is adjustable to >5 ppm and >15 ppm. If the oil content exceeds the adjusted limit the water is recirculated into the oily water tank. An intelligent process control adapts the capacity of the system to the changes of the product. A chemical dosing system is not necessary anymore.

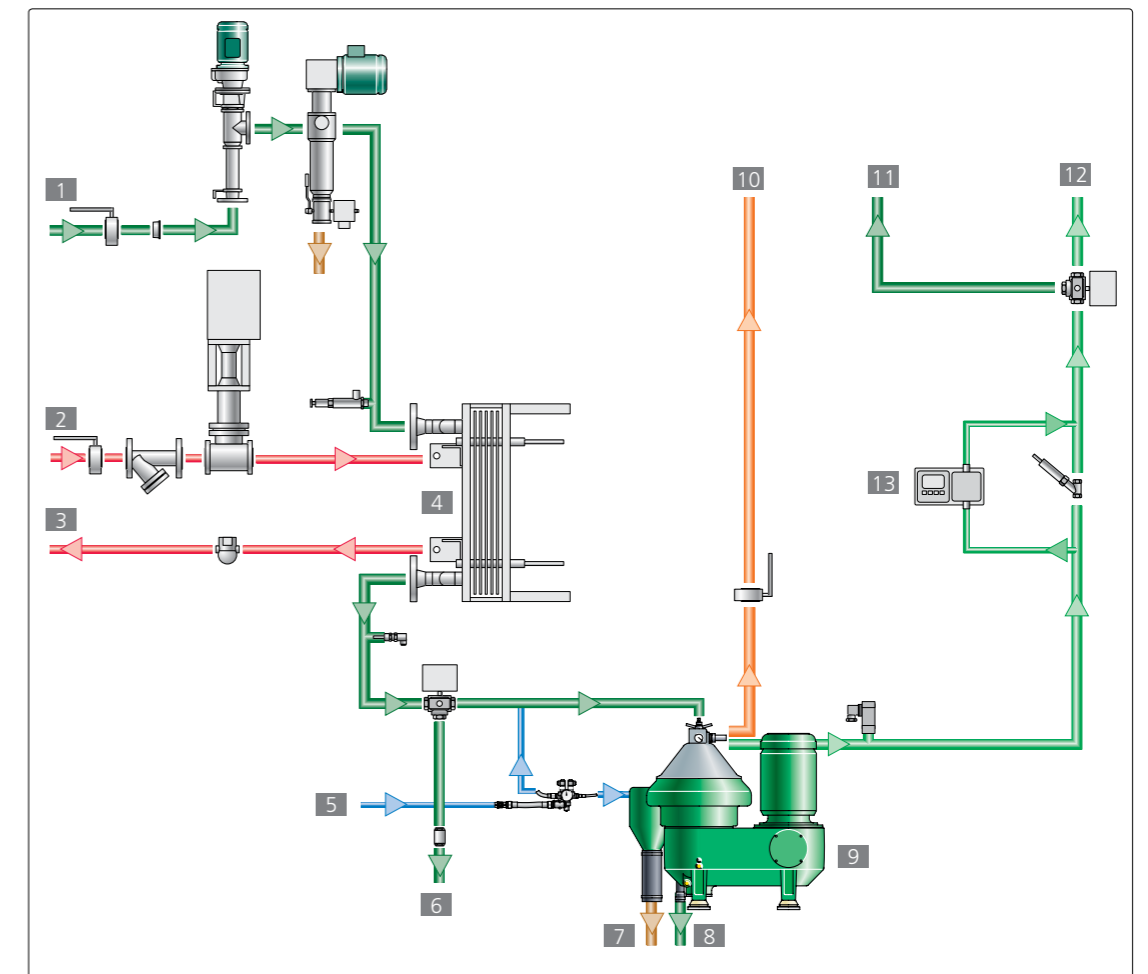

- | | | | |
|-------------------------|---------------------------|-----------------------------|------------------------------------|
| 1 Dirty bilgewater feed | 5 Operating water | 8 Operating water discharge | 11 Dirty bilgewater return |
| 2 Steam | 6 Dirty bilgewater return | 9 Self-cleaning separator | 12 Clean water discharge overboard |
| 3 Condensate | 7 Solids discharge | 10 Separated oil discharge | 13 Oil monitor |
| 4 Heater | | | |

Technologies to Protect the Sensitive Marine Ecosystem

Bilgewater treatment

The bilgewater treatment system is designed for ships which use high-density residual fuel oils. The system is supplied as a complete, self-contained Compact Unit incorporating all auxiliaries necessary for operation.

The main components of the system are:

- Self-cleaning centrifugal separator
- Frequency controlled feed pump
- Automatic self-cleaning filter
- Preheater
- Control panel
- Oil monitor for 5/15 ppm bilge alarms
- Pump/preheater unit
- Compact unit with sludge transfer unit
- Control and monitoring unit

Benefits of the centrifuge

- High separation efficiency due to large clarification area
- Controlled de-sludging with high solid content due to the GEA Westfalia Separator hydrostop system
- Gentle treatment due to the GEA Westfalia Separator softstream system
- Continuous separation of oil and water phase
- Self-cleaning effect of disc stack due to total ejection
- No impact of the ship's movement on the separation efficiency

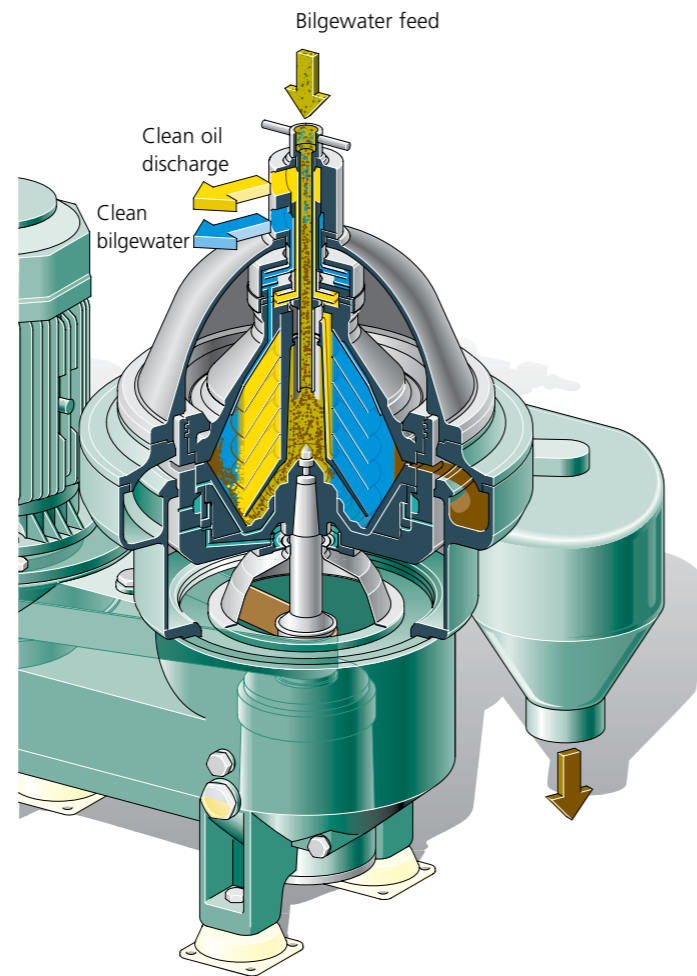

The Flexible Compact Unit Design is Suitable Both for Newbuildings or Retrofit

Separation results oily water treatment

With normal feed conditions, i.e.

solids content: < 0.1 percent

chloride content: < 30,000 ppm

pH: 6 – 9

and no excessive oil emulsions in the water phase, the residual oil content in the clean water discharge is 10 – 12 ppm. By varying the pump speed and separation temperature, it is possible to reduce the oil content even below 5 ppm.

Benefits

- Water outlet less than 5/15 ppm
- Reliable
- Easy handling
- Low maintenance cost
- Small dimensions
- Low weight
- Quick return on investment
- No adsorption filter and chemicals



The systems are approved by the latest IMO regulations and U.S. Coast Guard.

Optional in combination with GEA Westfalia Separator **SafetyMaster**: system-integrated or "stand-alone"

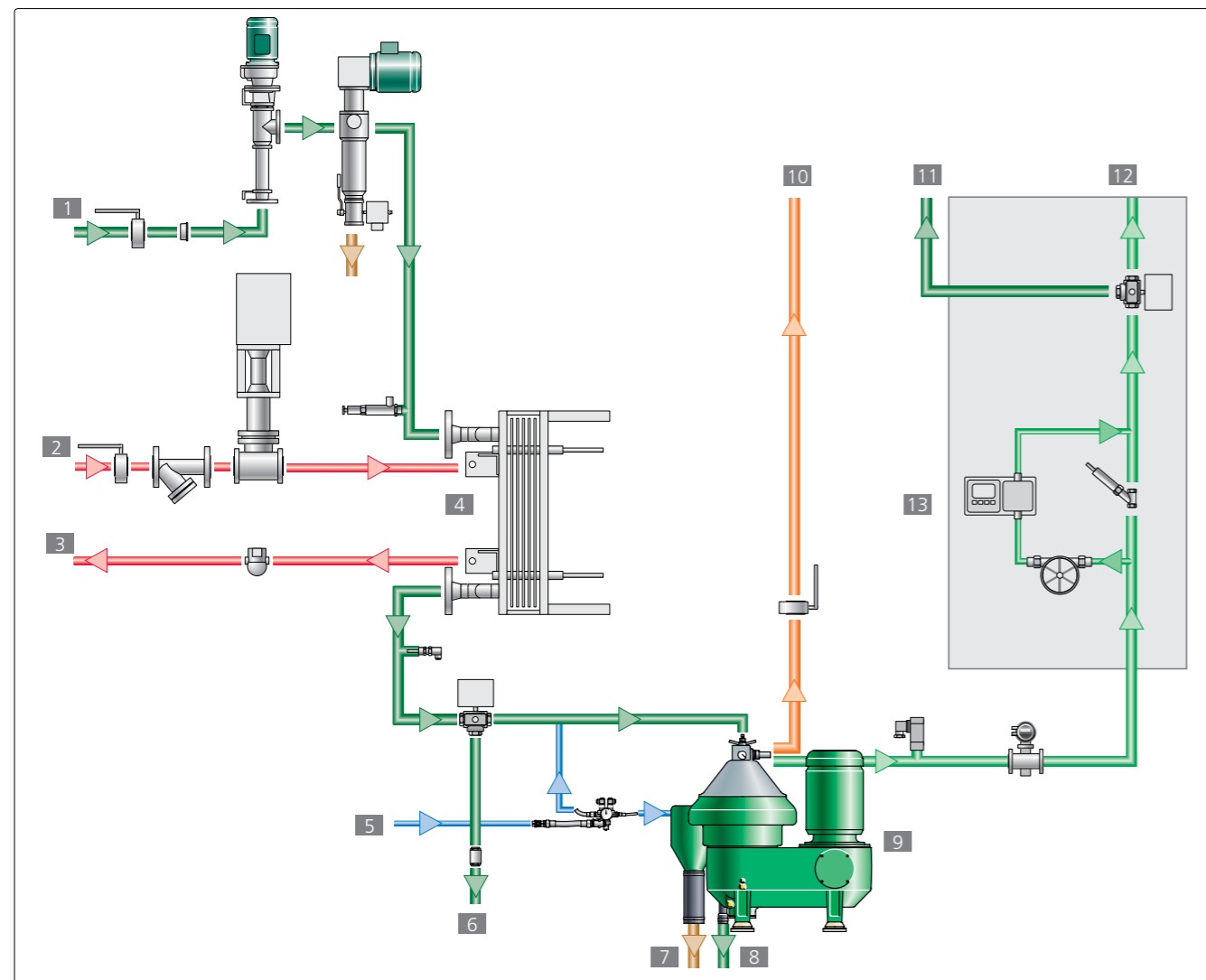

- | | | |
|-------------------------|-----------------------------|------------------------------------|
| 1 Dirty bilgewater feed | 6 Dirty bilgewater return | 11 Dirty bilgewater return |
| 2 Steam | 7 Solids discharge | 12 Clean water discharge overboard |
| 3 Condensate | 8 Operating water discharge | 13 Oil monitor |
| 4 Heater | 9 Self-cleaning separator | |
| 5 Operating water | 10 Separated oil discharge | |



GEA Westfalia Separator **SafetyMaster**

Additional security beyond the regulations of MARPOL

As an integrated part of the GEA Westfalia Separator **BilgeMaster**®-D series the GEA Westfalia Separator **SafetyMaster** provides additional security beyond the regulations of MARPOL against un-intended overboard discharge of oil polluted bilge-water. All components for sample taking, sample monitoring and overboard discharge control are combined and enclosed in a lockable stainless steel box. Further safety is provided by monitoring the flow to the oil monitor and supervising the function of the overboard valve.

A data recorder integrated in the separator control provides complete information of the status of the bilgewater treatment system over the last 18 months including the position of the vessel and the volume of water discharged.

The **SafetyMaster** is available optionally as integrated part of the **BilgeMaster**®-D series or as stand-alone unit.

Description of the system

The **SafetyMaster** is mounted on the control and monitoring unit and incorporates the oil monitor, the sample taking and sample return connection, the constant pressure valve, the sample water cooler, the flow switch in the sample water line and the overboard valve. The overboard valve is directly controlled by the oil monitor. In line of the alarm circuit are the flow switch and the end position switch of the door. The overboard valve is supervised by a micro switch giving an alarm and interrupting the separation process if the oil content is > 15 ppm while the valve is de-energized but not completely closed.



Inputs to the **SafetyMaster** are the 24 V power supply, the status signal separator running, compressed air, cleaning water and cooling water. The cooling water for the sample liquid can be connected either to the LT (low temperature) cooling system or to the cleaning water connection. Outputs from the **SafetyMaster** to the separator control are the analogue output 4 – 20 mA of the oil monitor, the status of the alarm circuit and the status of the position switch of the overboard valve. A flow meter is installed in the clean water outlet of the separator outside the GEA Westfalia Separator **SafetyMaster**. The flow is used to measure the volume discharged overboard and to monitor the condition of the feed pump, the bowl and the oil content in the product feed to the separator. All data of the status of the system including the position of the ship are recorded in a data log.

VBU – GEA Westfalia Separator ViscoBoosterUnits

Fuel oil conditioning system

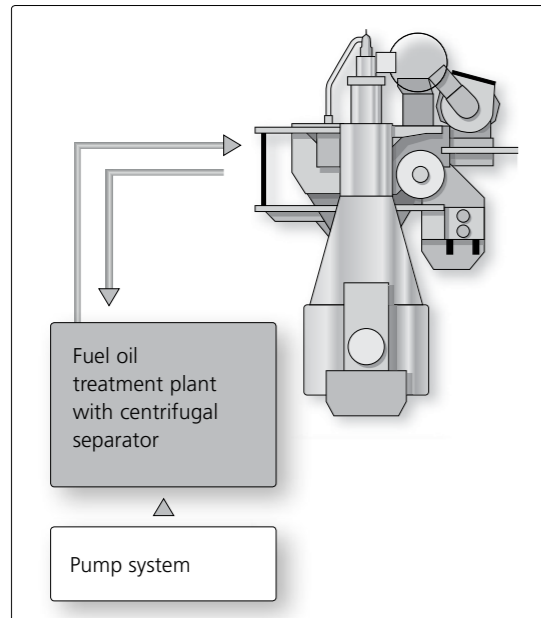

Complete System Between Service Tank and Engine

With the **ViscoBoosterUnits**, GEA Westfalia Separator Group offers a complete, compatible system from the service tank to the engine for safe and economic fuel oil treatment.

ViscoBoosterUnits are supplied as package systems. The **ViscoBoosterUnits** can be delivered as separate systems or as a complete module for the main engine and auxiliary engines for heavy fuel oil and diesel oil. They are designed for 24-hour unattended operation and meet the requirements of the classification societies.

- | | | |
|--------------------------|---------------------------------|------------------------------|
| 1 HFO | 7 Fuel to day tank | 13 Preheater |
| 2 MDO | 8 Fuel from engine | 14 Regulating valve |
| 3 Pressure control valve | 9 Automatic backflushing filter | 15 Steam or thermal oil |
| 4 Strainer | 10 Flow meter | 16 Steam trap |
| 5 Feeder pump | 11 Mixing/ Degassing tank | 17 Condensate or thermal oil |
| 6 Stand-by | 12 Booster pump | 18 Fuel to engine |

Efficient operation of ship and power station diesel engines requires optimum fuel supply. This key condition is accomplished by the **ViscoBoosterUnits** developed by GEA Westfalia Separator Group for fuel conditioning.

This unit consists of a treatment system that meets the fuel requirements between the clean oil tank and injection system for the main and auxiliary engines in terms of the required injection viscosity and temperature. Supply and booster pumps are provided for a stable system pressure.

The modules are designed for the different engines as well as to the required injection viscosity (approx. 10 – 24 cSt) and corresponding temperature (approx. 135 – 150°C).

VBU for marine application

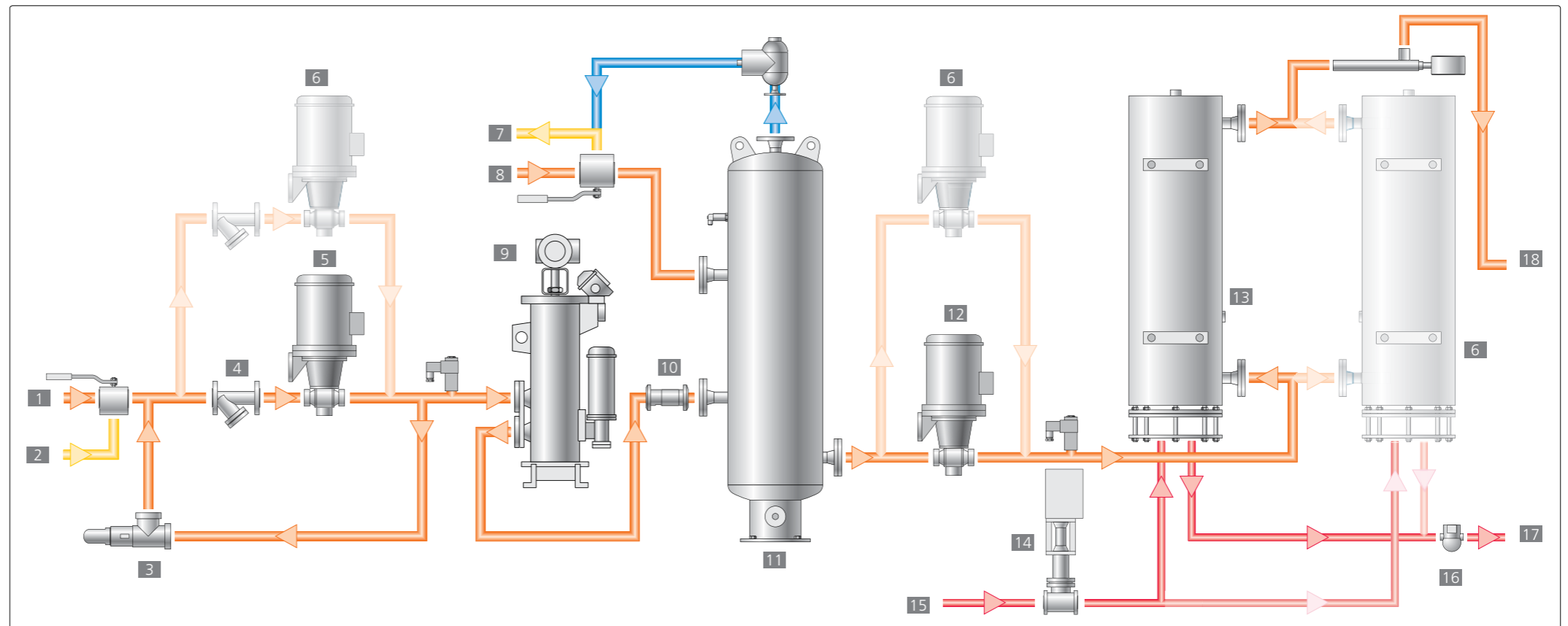

SWD – GEA Westfalia Separator SeaWaterDistiller

Water desalination system

Shore independent generation of fresh water on board by single stage evaporation technology.

Sea water is fed through the condenser, where it absorbs the latent heat of the condensing vapour. Some sea water is used as feed water for the evaporator whilst the remaining brine and non-condensable gases are discharged using a combined ejector. In the evaporator the sea water is heated up to the saturation temperature corresponding to the vacuum maintained by the ejector and a proportion is evaporated.

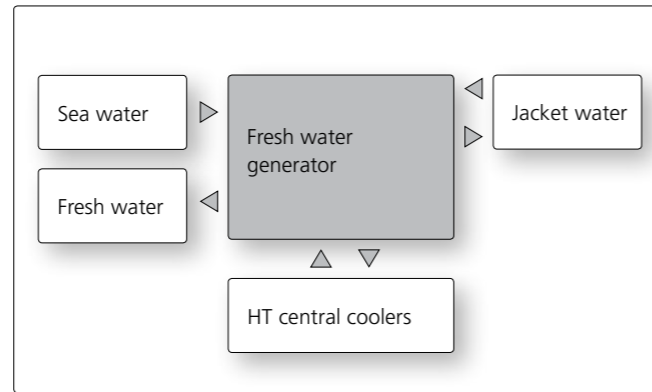

The evaporator generally utilizes the waste heat from the main diesel engine jacket water; however, other heating media may also be used (e.g. steam, thermal oil).

pump and discharged through the salinity measuring unit. Depending on the residual salt content of the distillate, it is either led to the distillate tank or, if the maximum allowable residual salt content is exceeded, back to the evaporator.

The vapour produced passes through the demister located in the upper casing to remove entrained droplets of water and is led to the condenser. The distillate is drawn from the condenser by the distillate

All parts in contact with sea water are constructed of corrosion-resistant materials (PP, stainless steel). The plates are made of titanium.



Single Stage Evaporating System

Benefits

- Compact
- Easy to operate
- Reliable
- Low weight
- Low maintenance costs
- Integrated anti-scaling system
- Corrosion-resistant materials
- High performance

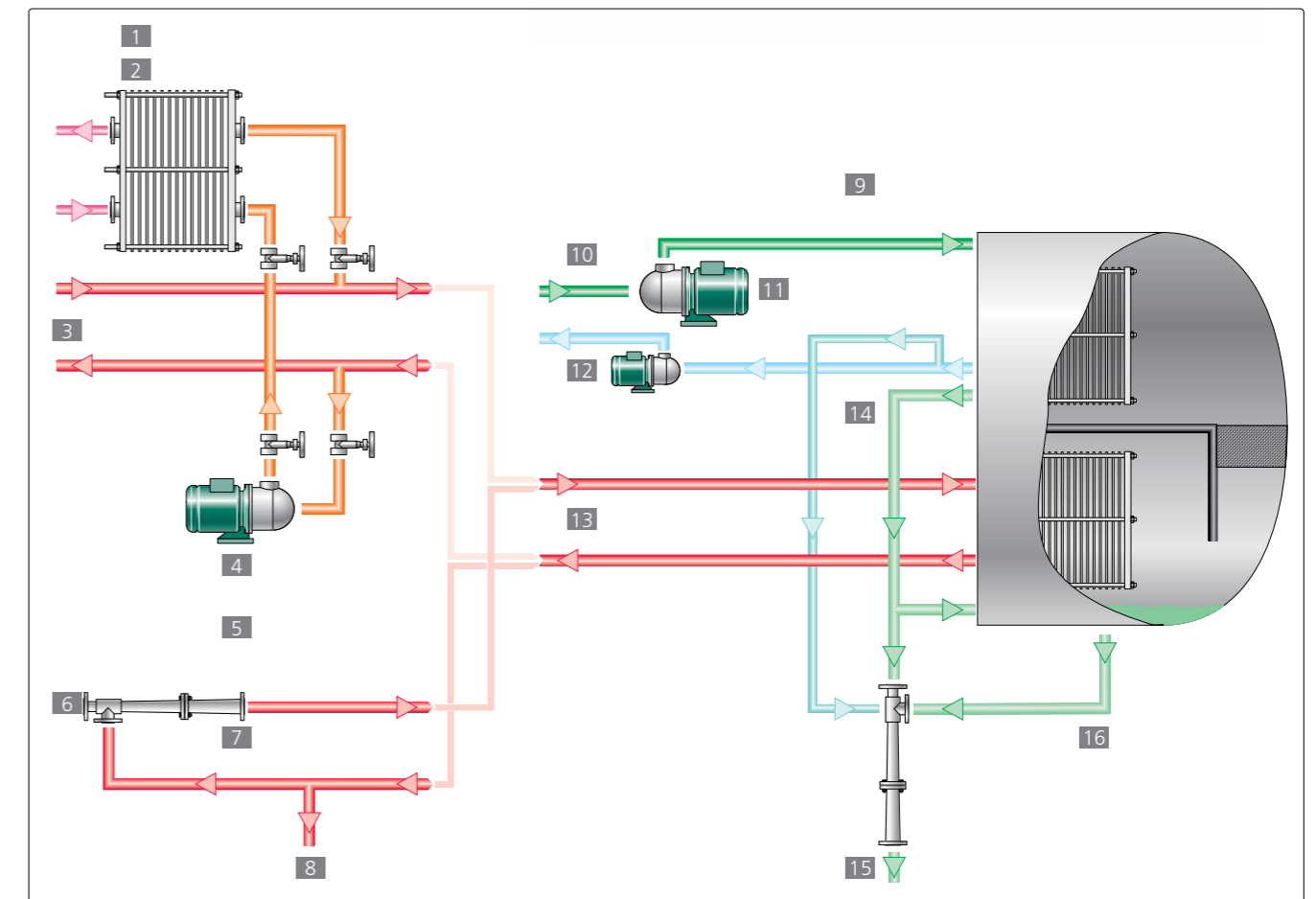

- | | | | |
|----------------------------------|-------------------------|------------------|--------------|
| 1 Thermal oil / hot water heated | 5 Steam heated | 10 Sea water | 15 Overboard |
| 2 Heat exchanger | 6 Steam | 11 Seawater pump | 16 Brine |
| 3 Jacket water | 7 Steam jet liquid pump | 12 Distillate | |
| 4 Circulation pump | 8 Condensate | 13 Heating water | |
| | 9 Jacket water heated | 14 Feed water | |

GEA Westfalia Separator **BallastMaster** ultraV

Mechanical ballast water treatment without the use and generation of chemicals

GEA Westfalia Separator **BallastMaster** ultraV provides you with an all-round, worry-free system which meets current and future IMO standards for ballast water treatment.

Just add water

With the GEA Westfalia Separator **BallastMaster** ultraV, it is very simple to ensure that there is only water in your ballast tanks – with no harmful organisms such as plankton, bacteria or viruses. Everything beneath the waves is under control, so you don't have to worry about it. Water goes in – easy.

Exceeding the standards

The IMO convention requires that new and currently operated ships must have ballast water management systems, with the law coming into full effect in 2016. These new guidelines may lead some ship owners and operators into uncharted territory. It's important to have a ballast water management system that is easy to use, complies with the terms of the convention and can be used for many years to come. The GEA Westfalia Separator **BallastMaster** ultraV is a highly efficient mechanical and physical system for treating ballast water, including water with a high concentration of organisms and sedimentary particles.

Two-step treatment for highest efficiency and safety

BallastMaster ultraV combines pre-filtration and UV-C. It doesn't need any chemical substances or generate any hazardous by-products. It uses a low pressure UV section, which is energy-efficient and requires no cooling.

Initial cleaning by mechanical filtration

In the first stage, a mechanical filtration process removes all organisms and sedimentary particles larger than 20 microns. This prevents sedimentary deposits from accumulating in the ballast water tanks, as the terms of the IMO convention stipulate. It also guarantees optimum results in the second stage, the ballast water disinfecting. The filter module is cleaned automatically by vacuum extraction (self-cleaning process).

Disinfection by means of UV-C

In the second stage, the pre-filtered ballast water is then disinfected by UV-C radiation. The monochromatic UV-C radiation (254 nm) eliminates organisms such as bacteria or phytoplankton. The micro cavitation delivered by ultrasonic guarantees that the biofilms and non-organic deposits in the UV-C tubes are cleaned off efficiently and remain permanently clean.

Future-proof compliance according to IMO D2 and USCG phase II

UV-C disinfection and ultrasonic cleaning provide consistent, high quality disinfecting in accordance with IMO guidelines. This ensures that harbour checks of any kind are passed without problems. The type approval for the GEA Westfalia Separator **BallastMaster** ultraV was issued by BSH on 19 December, 2011.

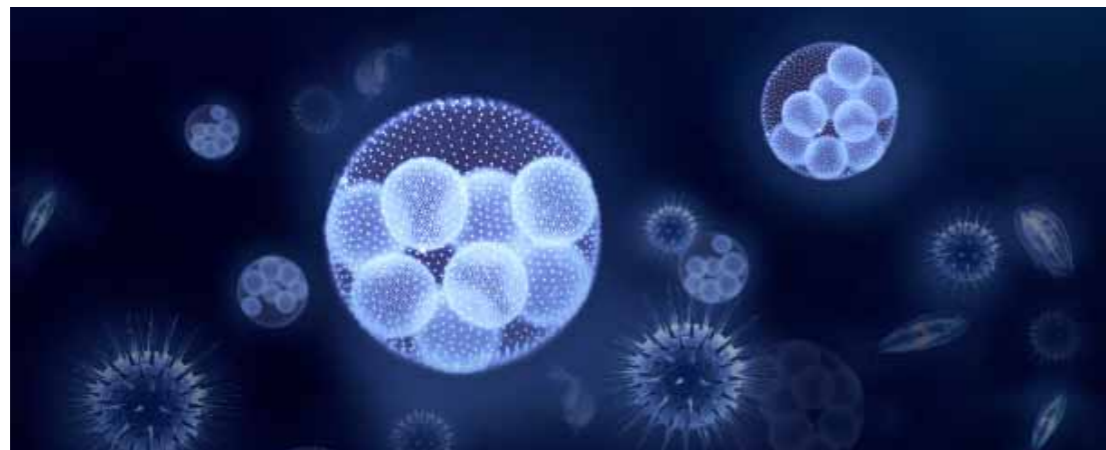

Ballasting

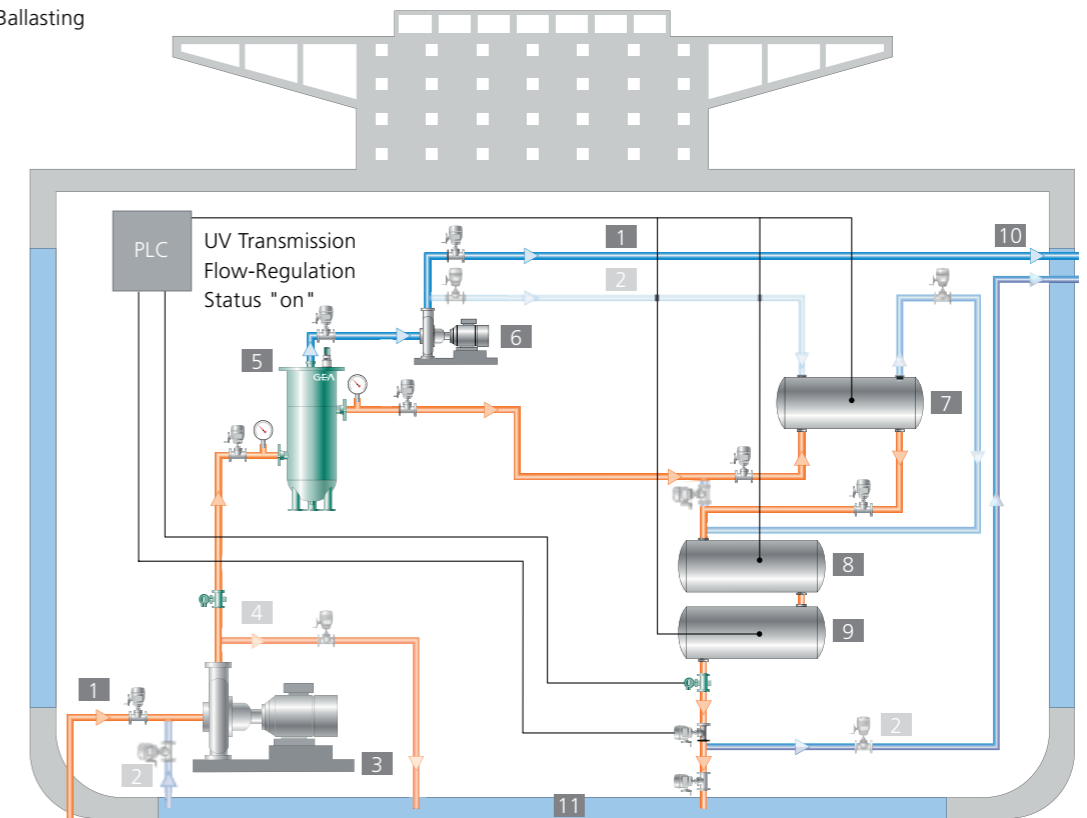

De-ballasting

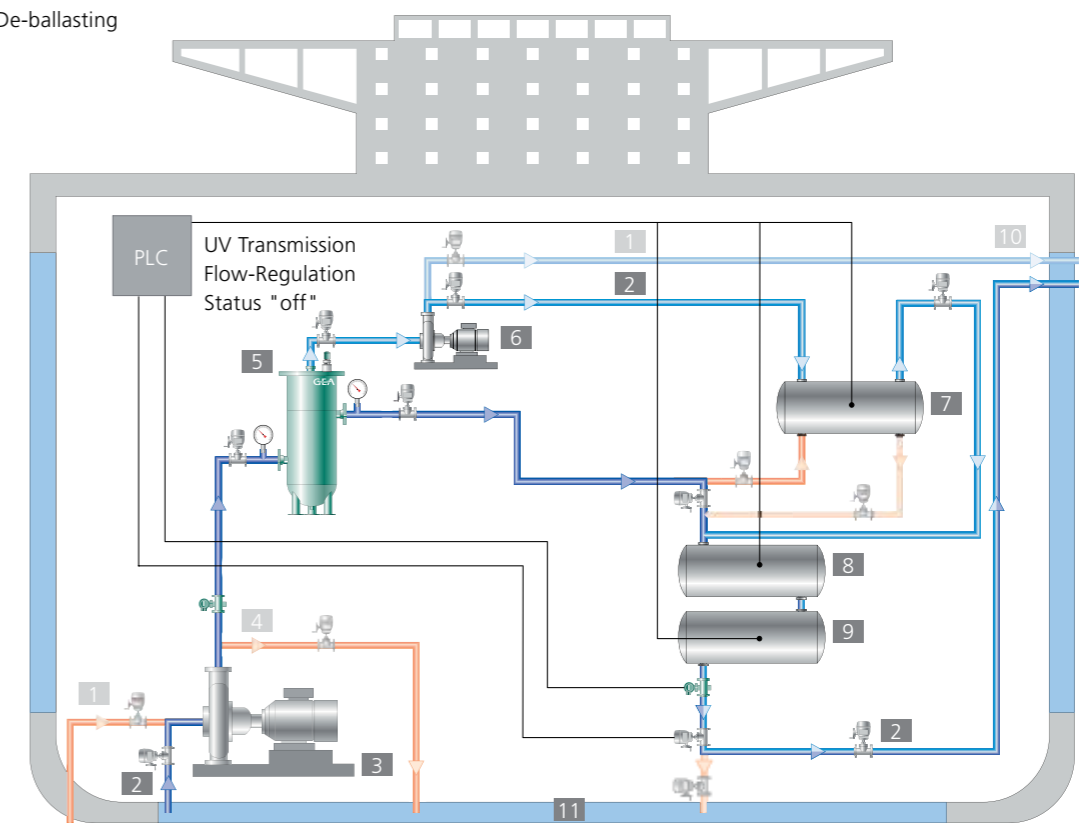

- | | | |
|-----------------|-----------------|----------------------------------|
| 1 Ballasting | 5 Filter 20 µm | 9 UV3 |
| 2 De-ballasting | 6 Transfer pump | 10 Back-flushing water overboard |
| 3 Ballast pump | 7 UV1 | 11 Ballast water tank |
| 4 By-pass | 8 UV2 | |



serv&care – Proactive Service for Optimum Reliability on Board

The proactive, risk-free services of serv&care optimize operating reliability and permanent availability of the drive systems.

Safety first: this is precisely what the service concept serv&care stands for.

Ship owners not only benefit from traditional services such as inspection, maintenance, original spare parts and repair work provided by the original manufacturer; they also benefit from proactive solutions which avoid risk, e.g. online and offline monitoring with GEA Westfalia Separator wewatch®. These preventive services are the best pre-condition for a smooth operation.

Enhanced process efficiency also follows from maximum operating reliability and machine availability. Accompanying modernization or upgrading to state-of-the-art technology also offer the option of boosting performance as required.

Training provided on site or in the modern training centre of GEA Westfalia Separator Group ensures that the plant operator's employees receive training in the proper handling of the high-tech installations. This provides additional safety.

Authorized workshops worldwide

And if problems occasionally occur or if a spare part is required at short notice, the specialists are able to attend to the ships quickly. This is ensured by a global network with more than 50 sales and service companies. Authorized workshops are able to service every location in the world at short notice.

serv&care accordingly makes for maximum operating reliability, machine availability, process efficiency and budget security. And these benefits are provided throughout the entire life cycle of the entire installation.

Service from the original manufacturer:

- Service engineers quickly on site
- Extensive service network
- Risk avoidance through service provided by the original manufacturer
- Proactive solutions
- Upgrading to boost performance
- Crew training

In addition to traditional services such as maintenance or repair, serv&care also provides solutions which avoid risk and with which the installation availability can be proactively assured.

serv&care



We live our values.

Excellence • Passion • Integrity • Responsibility • GEA-versity

GEA Group is a global engineering company with multi-billion euro sales and operations in more than 50 countries. Founded in 1881, the company is one of the largest providers of innovative equipment and process technology. GEA Group is listed in the STOXX® Europe 600 Index.

GEA Mechanical Equipment

GEA Westfalia Separator Group GmbH

Werner-Habig-Str. 1, 59302 Oelde, Germany
Phone +49 2522 77-0, Fax +49 2522 77-1778
www.gea.com